

BUILDING SITE PLAN (EXISTING)

INTERIOR TENANT IMPROVEMENT AREA: 3,104 SF
IMPROVED PATIO AREA: 691 SF
TOTAL SUP FLOOR AREA: 3,795 SF

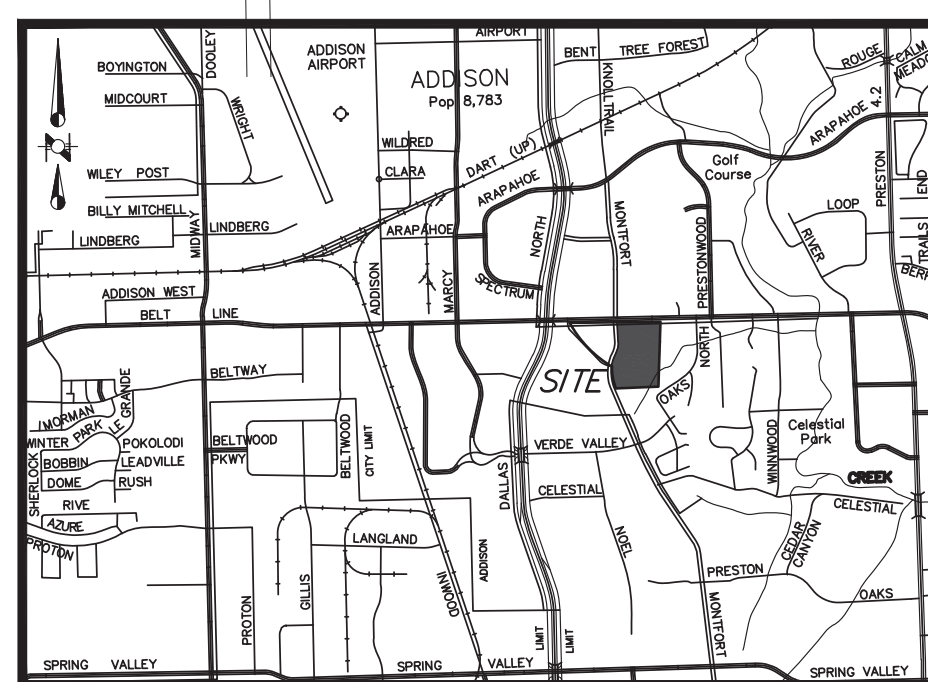

OWNER:
NORTHWOOD RETAIL, LLC
8080 PARK LANE, #600
DALLAS, TEXAS 75231
PH: (469)-828-3313
RYAN MUSCOTT

APPLICANT/TENANT/DESIGN:
MENDOCINO FARMS TEXAS
13103 VENTURA BLVD #100
STUDIO CITY, CA 91604
(415) 545-8840
CHRIS KONECNY

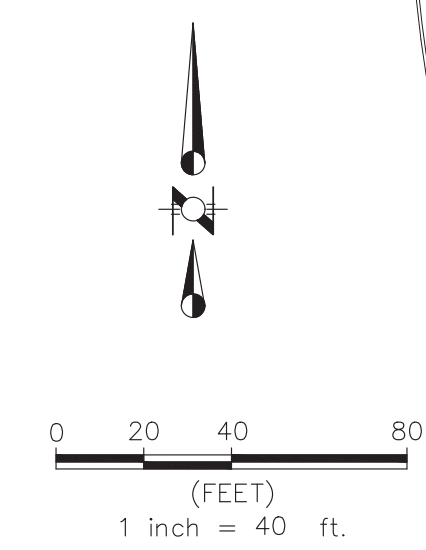
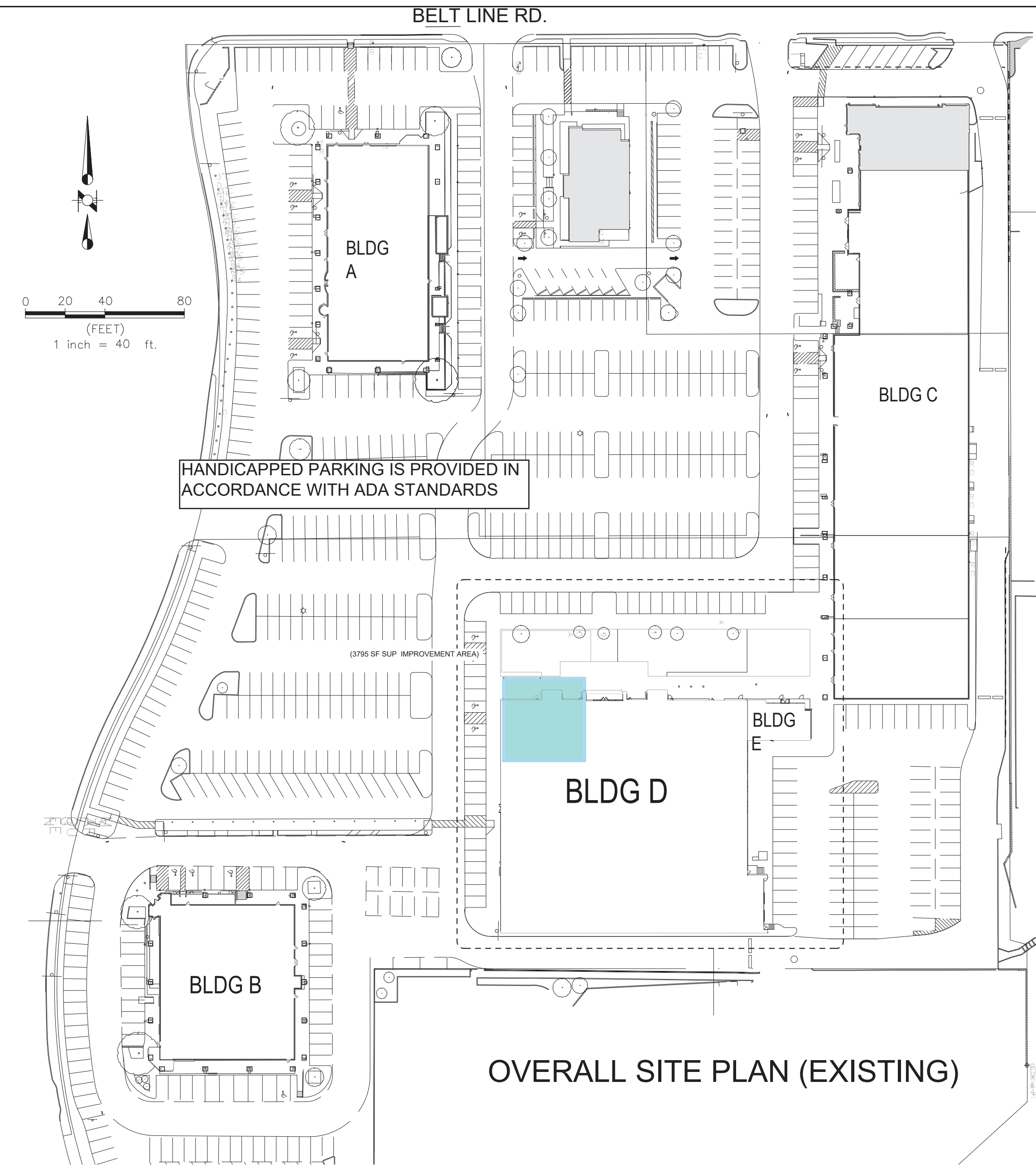

SITE DATA SUMMARY TABLE	
LOT AREA (SF)	75,571
LOT AREA (ACRE)	10.88
EXISTING ZONING	PD
PROPOSED ZONING	PD
PROPOSED USE	RESTAURANT
BUILDING AREA (SF)	135,000
LOT COVERAGE	21.8%
PARKING RATIO	1/200
REQ'D PARKING	675
PROVIDED PARKING	768
STALL SIZE	8.5x17'

- TOWN OF ADDISON SITE PLAN NOTES:**
- Any revision to this plan will require Town approval and will require revisions to any corresponding plans to avoid conflicts between plans.
 - Open storage, where permitted, shall be screened in accordance with the Zoning Ordinance.
 - Buildings with an aggregate sum of 5,000 square feet or greater on a lot shall have automatic fire sprinklers installed throughout all structures. Alternative fire protection measures may be approved by the Fire Department.
 - All signage is subject to Town approval.
 - All fences and retaining walls shall be shown on the site plan and are subject to Building Inspection Division approval.

HANDICAPPED PARKING IS PROVIDED IN ACCORDANCE WITH ADA STANDARDS

ACTION		
APPROVED	DENIED	
STAFF	Date	Initials
COUNCIL	Date	Initials

See the Staff Approval Letter or Council Result Memo for any conditions associated with the approval of the project.

MENDOCINO FARMS SANDWICH MARKET

PRESTONWOOD PLACE
5294 Belt Line Road Suite 105
NORTHWOOD RETAIL, LLC
TOWN OF ADDISON, TEXAS

SITE PLAN

PREPARED: 6/4/2020
TOWN PROJECT NUMBER
1814-SUP

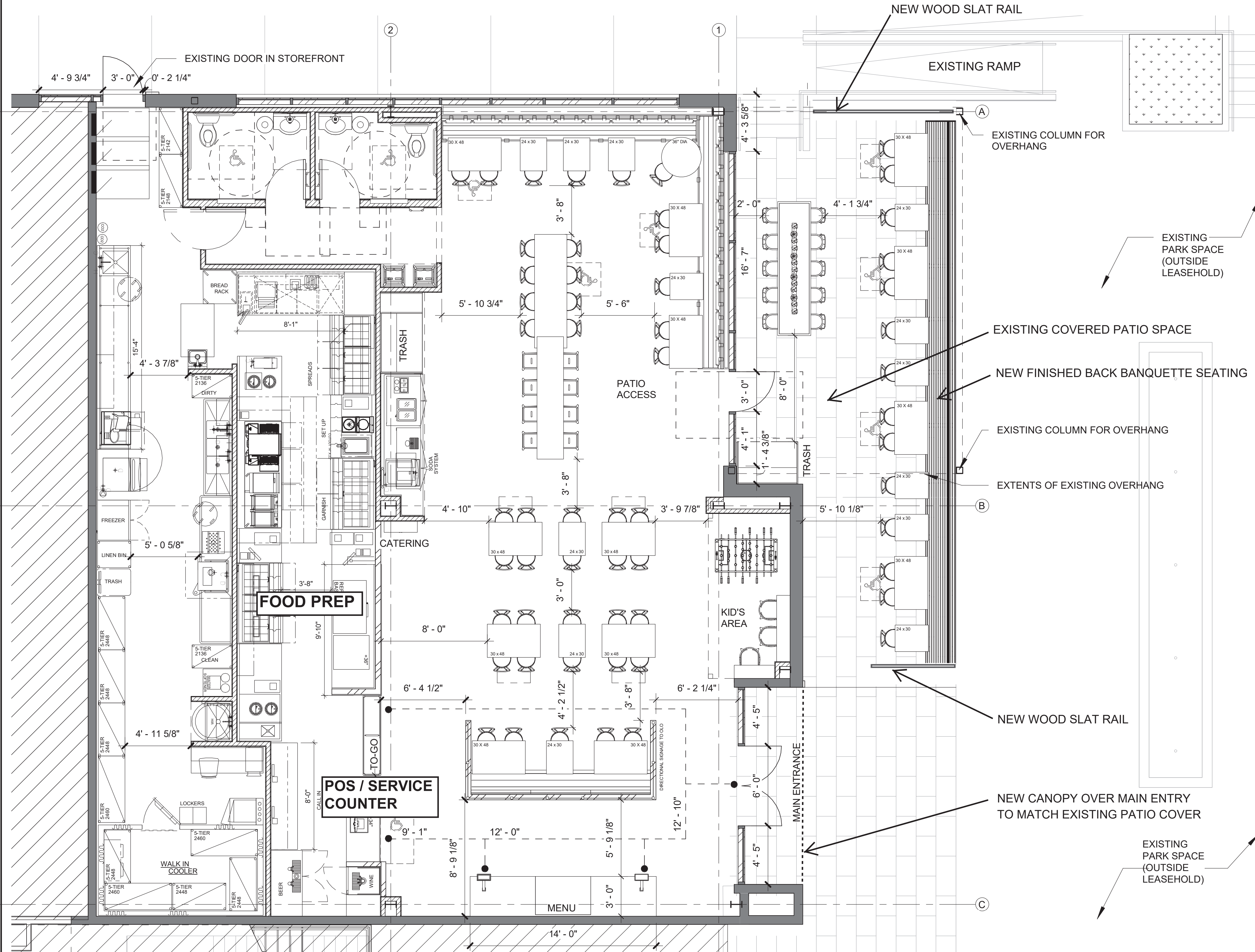

SEAT COUNT
 DINING: 72
 PATIO: 38
 TOTAL: 110

INTERIOR FLOOR AREA
 FRONT OF HOUSE: 1687 SF
 BACK OF HOUSE: 1417 SF
 TOTAL: 3104 SF

PATIO AREA
 TOTAL: 691 SF

TOTAL SUP AREA:
 3795 SF

FLOOR PLAN

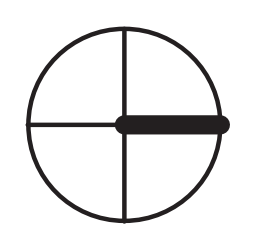
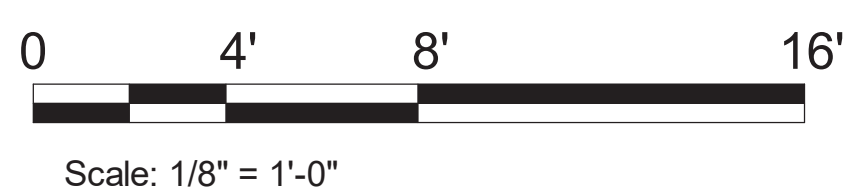

OWNER:
 NORTHWOOD RETAIL, LLC
 8080 PARK LANE, #600
 DALLAS, TEXAS 75231
 PH: (469)-828-3313
 RYAN MUSCOTT

APPLICANT/TENANT/DESIGN:
 MENDOCINO FARMS TEXAS
 13103 VENTURA BLVD #100
 STUDIO CITY, CA 91604
 (415) 545-8840
 CHRIS KONECNY

PREPARED: 6/4/2020
 TOWN PROJECT NUMBER
 1814-SUP

*MENDOCINO FARMS
 SANDWICH MARKET*

PRESTONWOOD PLACE
 5294 Belt Line Road Suite 105
 NORTHWOOD RETAIL, LLC
 TOWN OF ADDISON, TEXAS

FLOOR PLAN

TOP BLDG D.
140' - 0"

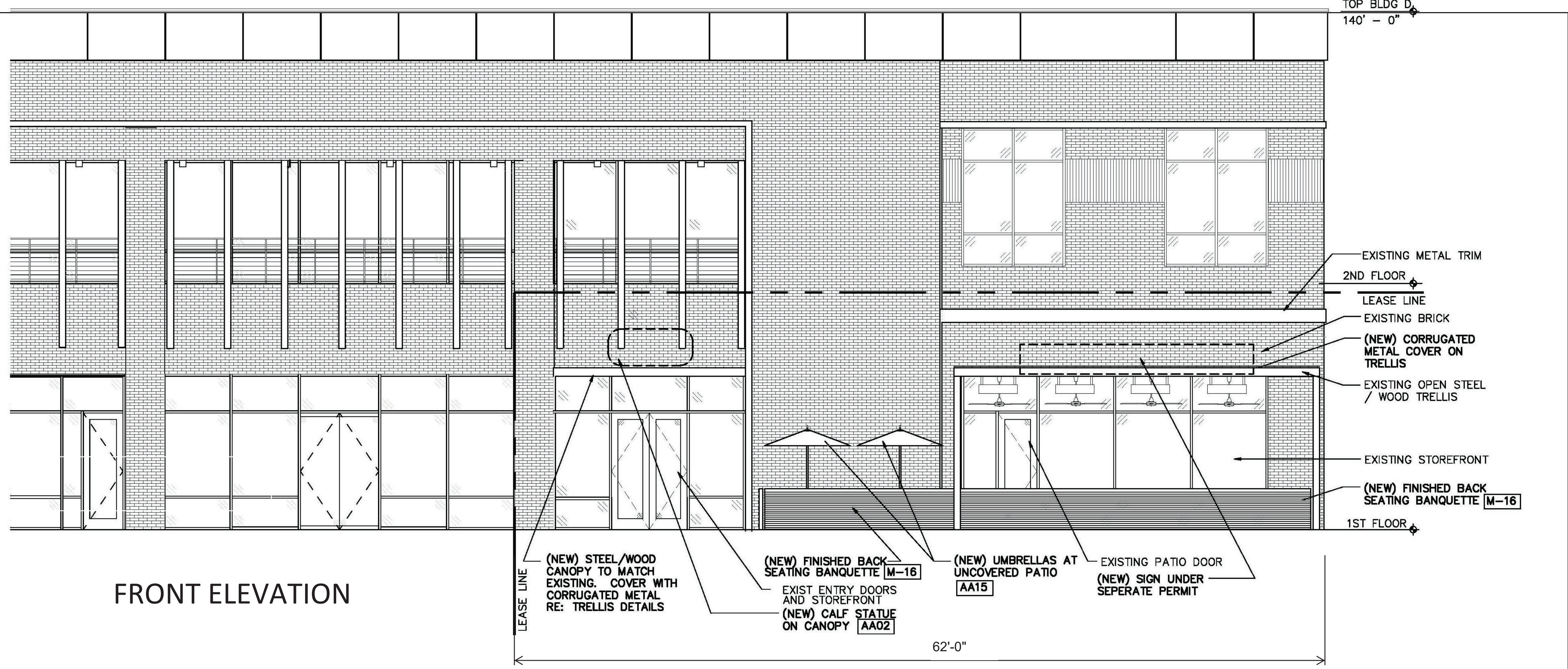

FRONT ELEVATION

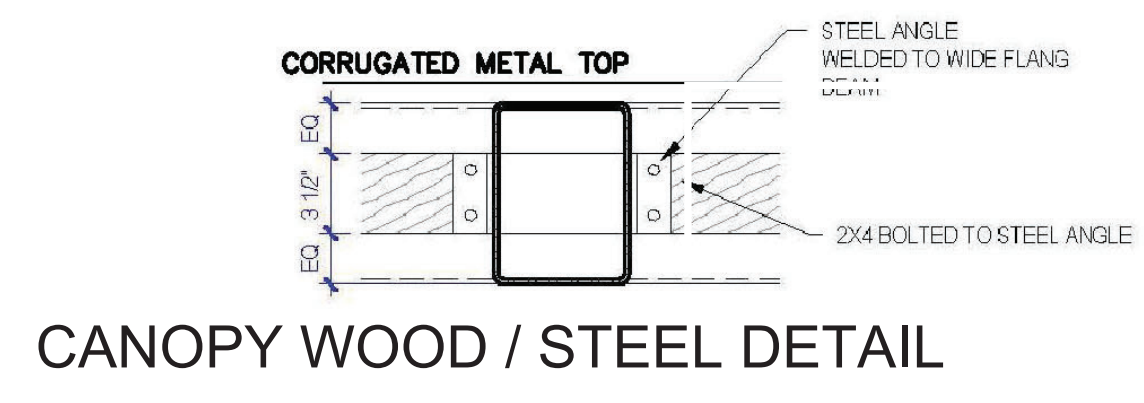

CANOPY WOOD / STEEL DETAIL

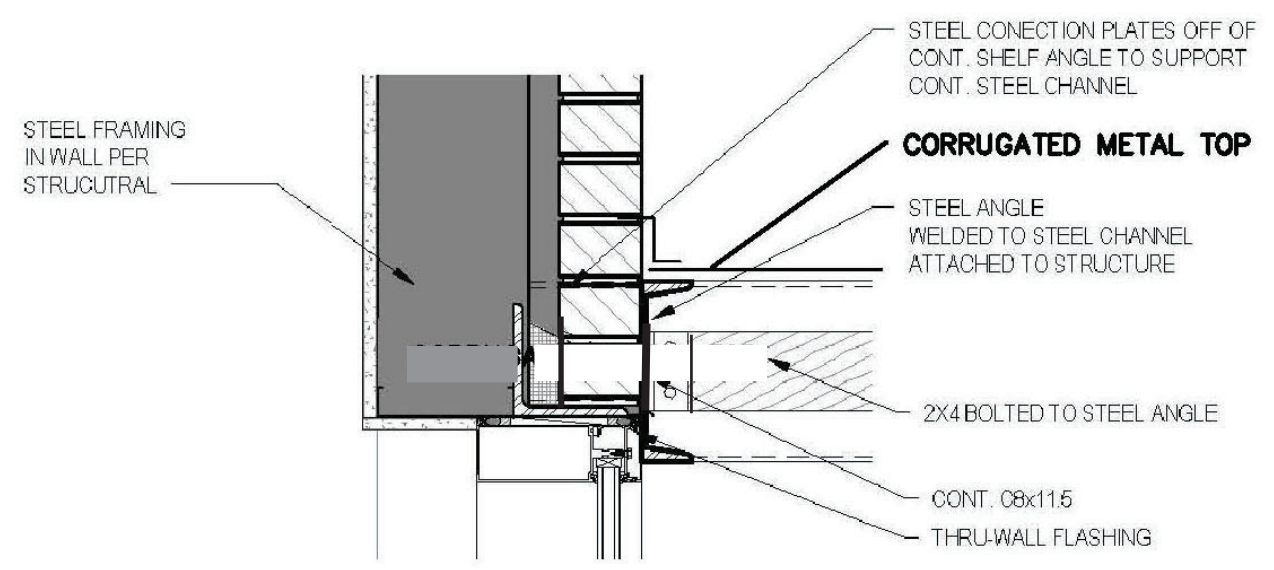

CANOPY BUILDING CONNECTION DETAIL

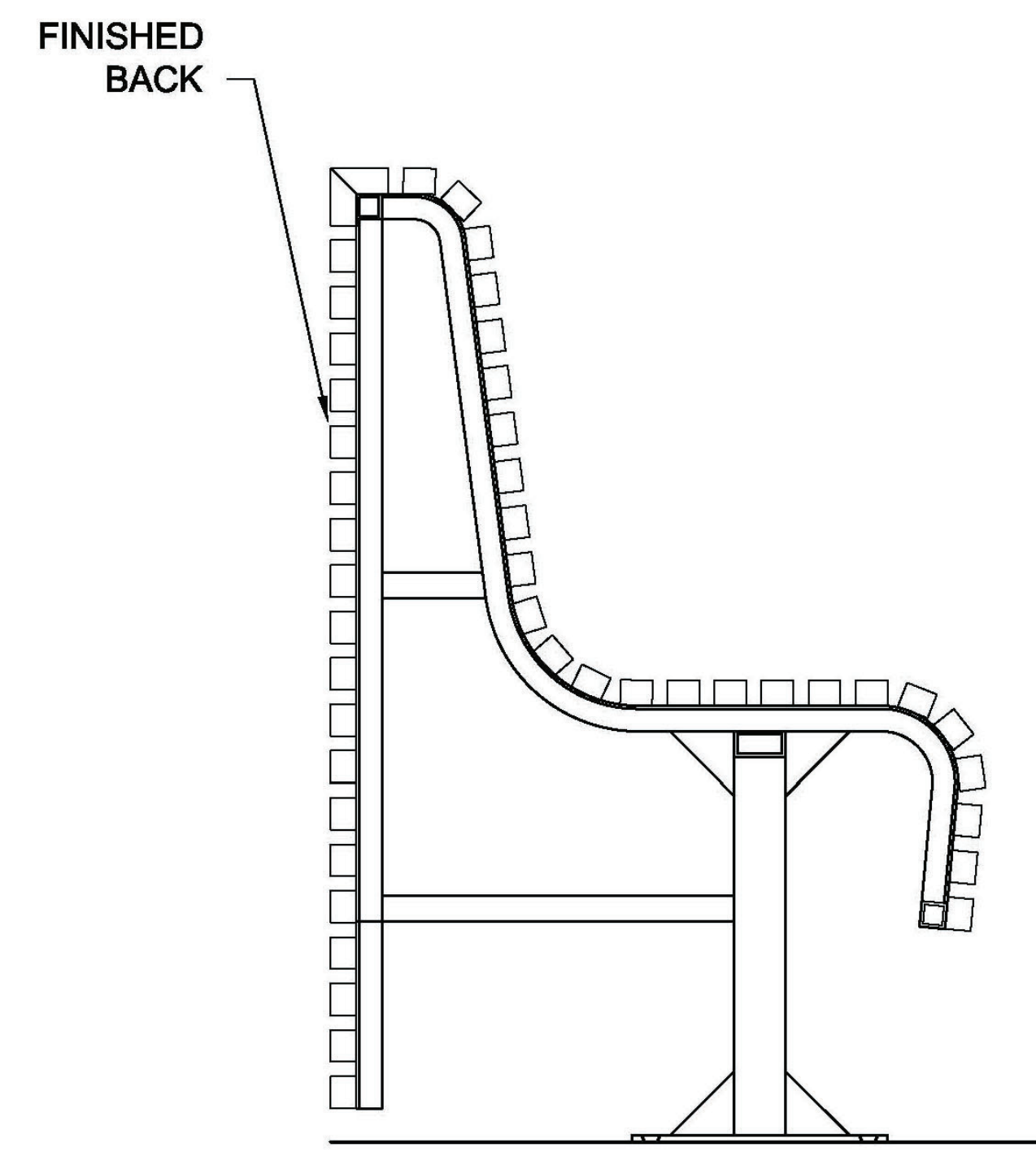

PATIO BANQUETTE DETAIL

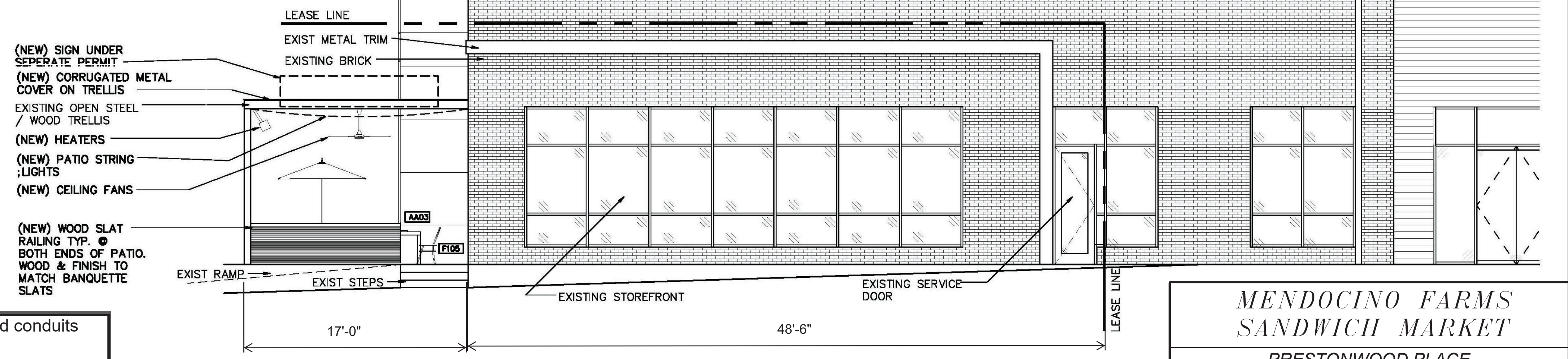

SIDE ELEVATION

- FACADE PLAN NOTES**
- This Facade Plan is for conceptual purposes only. All building plans require review and approval by Development Services.
 - All mechanical units shall be screened from public view as required by the Zoning Ordinance
 - When permitted, exposed utility boxes and conduits shall be painted to match the building
 - All signage areas and locations are subject to approval by Development Services
 - Roof access shall be provided internally, unless otherwise permitted by the Chief Building Official

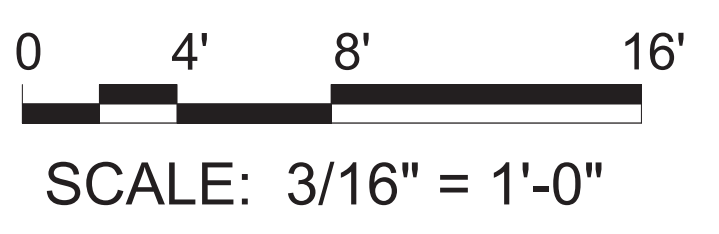

OWNER:
NORTHWOOD RETAIL, LLC
8080 PARK LANE, #600
DALLAS, TEXAS 75231
PH: (469)-828-3313
RYAN MUSCOTT

APPLICANT/TENANT/DESIGN:
MENDOCINO FARMS TEXAS
13103 VENTURA BLVD #100
STUDIO CITY, CA 91604
(415) 545-8840
CHRIS KONECNY

PREPARED: 6/4/2020
TOWN PROJECT NUMBER
1814-SUP

*MENDOCINO FARMS
SANDWICH MARKET*

PRESTONWOOD PLACE
5294 Belt Line Road Suite 105
NORTHWOOD RETAIL, LLC
TOWN OF ADDISON, TEXAS

ELEVATIONS