

ADDENDUM NO. 1

RAWHIDE CREEK BASIN DRAINAGE AND ADA IMPROVEMENTS

TOWN OF ADDISON, TEXAS PUBLIC WORKS AND ENGINEERING SERVICES BID NUMBER 22-75

08/18/2022



TO: All Plan Holders of Record

This Addendum forms part of the Contract Documents and modifies the Contract Documents and Specifications, as noted below. Acknowledge receipt of the Addendum in the space provided on the Proposal Form and on the outer envelope of the Proposal. Failure to acknowledge receipt of this Addendum may subject the Bidder to disqualification.

This Addendum consists of 2-pages and 2-attachments.

CHANGES TO BID PACKAGE

1. Section AB - Advertisement for Bids
 - a. Updated “Proposal” to “Bid”. Void previous and replace attached page: AB-2.
2. Section IB - Instructions to Bidders
 - a. Updated “Proposal” to “Bid”. Void previous and replace attached pages: IB-2 to IB-10.
 - b. Added “Scoring Criteria” to H. EVALUATION CRITERIA AND AWARDS OF THE PROPOSAL. Refer to replacement above.
3. Section PF - Proposal Form
 - a. Updated Bid Item No. 53 “UNIT” from “EA” to “AL” (for Allowance). Also, updated Bid Item No. 53 “UNIT PRICE”, “BID AMOUNT”, and “TOTAL (BASE BID)” to reflect the \$3,500 Allowance. Void previous and replace attached page: PF-5.
 - b. Updated “Proposal” to “Bid”. Void previous and replace attached page: PF-6.
4. Section GTC- General Terms and Conditions
 - a. Updated “Proposal” to “Bid”. Void previous and replace attached pages: GTC-1 to GTC-3, GTC-8 to GTC-9, and GTC-12.
5. Section SP - Special Provisions
 - a. Updated “Proposal” to “Bid”. Void previous and replace attached pages: SP-3, and SP-8, SP-23 to SP-24, SP-27, SP-50 to SP-51, and SP-60 to SP-61.
 - b. Removed “Bid Item No. 53” description, due to “Allowance”. Void previous and replace attached pages: SP-21 to SP-67. Insert attached page SP-68. Also, refer to replacement above.

6. Void and Replace Bid Item Tab excel form with form name “Project 2202-01C, Bid No. 22-75 Bid Items_A-01”.

CHANGES TO PLAN SET

1. VOID PREVIOUS AND REPLACE ATTACHED PLAN SHEET: 2 with the plan sheet attached. Updated Bid Item No. 53 “UNIT” from “EA” to “AL” (for Allowance). Any revisions have been noted on each sheet.
2. VOID PREVIOUS AND REPLACE ATTACHED PLAN SHEET: 41 with the plan sheet attached. Updated “SD LINE ‘B’ Profile from STA 12+48.35 to END. Any revisions have been noted on each sheet.

END OF ADDENDUM NO. 1

ADVERTISEMENT FOR BIDS

1. The Town of Addison is requesting submission for proposals for the Bid of the Addison Rawhide Creek Basin Drainage and ADA Improvements from Brookwood Ln to Waterside Ct. **Proposals will be accepted until 2:00 p.m., Tuesday, August 30, 2022** at the Finance Building, 5350 Belt Line Rd., Dallas, Texas 75254 – Attention Purchasing Department, at which time responders names and proposals will be publicly read aloud. Late proposals will not be considered. The plans, specifications, quantities, pre-proposal time and date, and other information are available on www.civcastusa.com. The plans, specifications, and quantities for the work to be done are also on file with Public Works & Engineering Services Department, Town of Addison, 16801 Westgrove Drive, Addison, Texas 75001, and such plans, specifications, and quantities may be examined without charge. The Town of Addison reserves the right to waive any formalities, to reject any and all proposals, and to select the proposal deemed most advantageous to the Town of Addison.
2. The Contractor shall identify his proposal on the outside of the envelope by writing the words **PUBLIC WORKS AND ENGINEERING SERVICES BID NUMBER 22-75, ADDISON RAWHIDE CREEK BASIN DRAINAGE AND ADA IMPROVEMENTS FROM BROOKWOOD LN TO WATERSIDE CT**

PAPER PROPOSALS SHALL BE REQUIRED.

3. Proposals shall be accompanied by a bid bond in an amount not less than five percent (5%) of the total maximum bid from a reliable surety company licensed by the State of Texas to act as a Surety and be listed on the current U.S. Treasury Listing of Approved Sureties, or a Binder of Insurance executed by a surety company licensed by the State of Texas to act as a surety or its authorized agent as a guarantee that the bidder will enter into a contract and execute a Performance Bond and Payment Bond within ten (10) days after notice of award of contract to him.
4. Plans, specifications and bidding documents may be downloaded from www.civcastusa.com. The Town of Addison is a "free buyer", meaning that prospective bidders need only a free registration to sign up for plan updates. Bidders assume all risk for acquiring specs and/or plans from third party sites and plan rooms, as only www.civcastusa.com will be directly updated by Addison.
5. The right is reserved by the Mayor and the City Council as the interests of the City may require to reject any or all proposals and to waive any formality in proposals received and to select the proposal deemed most advantageous to the City.
6. The Bidder (Proposer) must supply all the information required by the Proposal Form.
7. A Performance Bond, Labor and Material Payment Bond, and Maintenance Bond will be required by the Owner; each Bond shall be in the amount of 100% of the total contract amount. Bonds shall be issued by a surety company licensed by the State of Texas to act as a Surety and be listed on the current U.S. Treasury Listing of Approved Sureties.
8. The Bidder (Proposer) must supply all the information required by the Bidder Qualification Statement.
9. **Pre-proposal meeting will be held on Tuesday, August 16, 2022 at 2:00 p.m. in the Town of Addison Service Center 1st Floor Large Conference Room located at 16801 Westgrove Drive, Addison, TX 75001. All perspective bidders are strongly encouraged to attend. A site visit will follow this meeting.**

INSTRUCTIONS TO BIDDERS

- A. PROJECT: ADDISON RAWHIDE CREEK BASIN DRAINAGE AND ADA IMPROVEMENTS FROM BROOKWOOD LN TO WATERSIDE CT.,** in the Town of Addison. The proposals will be evaluated as stated in Section "O" of these Instructions to Bidders.
- 1. PROJECT DESCRIPTION:** The project consists of constructing storm drain improvements and ADA upgrades to sidewalks, driveways and ramps in accordance with the plans and specifications. The project also includes an underground detention and landscape improvements near Brookwood Lane.
- B. PROPOSALS:** Proposals must be in accordance with these instructions in order to receive consideration.
- C. DOCUMENTS:** Bidding Documents include the Project Manual (consisting of the Advertisement for Bids, these Instructions to Bidders, Proposal Forms, Reference Form, Contract Agreement, Performance Bond, Payment Bond, Maintenance Bond, Contractor's Affidavit of Bills Paid, General Provisions, Special Provisions, Project Sign, and Technical Specifications), a Waiver of Lien, Drawings, and Addenda which may be issued by the Town of Addison during the bidding period. Bidding Documents may be viewed and/or obtained under the terms and conditions set forth in the Advertisement for Bids, Section AB of this Project Manual.
- D. EXAMINATION OF DOCUMENTS AND SITE:** Bidders shall carefully examine the Bidding Documents and the construction site to obtain firsthand knowledge of the scope and the conditions of the Work. Each Contractor, Subcontractor and Sub-subcontractor, by submitting a proposal to perform any portion of the Work, represents and warrants that he has examined the Drawings, Specifications (Project Manual) and the site of the Work, and from his own investigation has satisfied himself as to the scope, accessibility, nature and location of the Work; the character of the equipment and other facilities needed for the performance of the Work; the character and extent of other work to be performed; the local conditions; labor availability, practices and jurisdictions; and other circumstances that may affect the performance of the Work. No additional compensation will be allowed by the Owner for the failure of such Contractor, Subcontractor or Sub-subcontractor to inform himself as to conditions affecting the Work.
- E. INTERPRETATION OF DOCUMENTS:** If any person contemplating submitting a proposal for the proposed Contract is in doubt as to the meaning of any part of the Drawings, Specifications (Project Manual) or other proposed Contract Documents, he may submit questions to the Town of Addison, no later than 5:00 p.m. on Wednesday, August 24, 2022. All questions received by this deadline will be answered by 5:00 p.m. on Monday, August 26, 2022. Bidders should act promptly and allow sufficient time for a reply to reach them before preparing their proposals. Any interpretation or clarification will be in the form of an Addendum duly issued. No alleged verbal interpretation or ruling will be held binding upon the Owner.

F. SUBSTITUTIONS: Conditions governing the submission of substitutions for specific materials, products, equipment and processes are in the Special Provisions. Requests for substitutions must be received by the Town of Addison seven (7) calendar days prior to the established proposal date.

G. ADDENDA: Interpretations, clarifications, additions, deletions and modifications to the Documents during the bidding period will be issued in the form of Addenda and a copy of such Addenda will be released through www.civcastusa.com. It will be the responsibility of each person who has been issued a set of bid documents to secure all Addenda from www.civcastusa.com. Addenda will be a part of the Bidding Documents and the Contract Documents, and receipt of them shall be acknowledged in the Bid Form. All such interpretations and supplemental instructions will be in the form of written addenda to the contract documents which, if issued, will be released through www.civcastusa.com. not later than three (3) calendar days prior to the date fixed for the opening of proposals. If any bidder fails to acknowledge the receipt of such addenda in the space provided in the bid form, his proposal will nevertheless be construed as though the receipt of such addenda had been acknowledged.

H. EVALUATION CRITERIA AND AWARDING OF THE PROPOSAL: For best value, the Final Request for Proposal and award will not only look for the lowest bidder, the proposals will be scored by an evaluation committee consisting of Town staff, using criteria and associated weights.

- The Town may consider more factors than just price in awarding a contract in accordance with the requirements for competitive bidding under the Local Government Code Section 252.043. The criteria that will be considered are:
 - the price;
 - the offeror's experience and reputation;
 - the quality of the offeror's goods or services;
 - the impact on the ability of the Town to comply with rules relating to historically underutilized businesses;
 - the offeror's safety record;
 - the offeror's proposed personnel;
 - whether the offeror's financial capability is appropriate to the size and scope of the project; and
 - any other relevant factor specifically listed in the request for proposals, proposals, or qualifications.
- Scoring Criteria:
 - 50% Price
 - 25% Experience with Similar Projects
 - 15% Proposed Project Team
 - 10% References (within the last 5-years)

I. COMPLETION TIME: The selected contractor shall use the time period between the awarding of the contract at Town Council and the date of Notice to Proceed to submit materials and shop drawings for approval by **CRIADO & Associates, Inc. Criado &**

Associates, Inc. shall review and return these submittals in the most expedient manner possible to accommodate immediate material ordering.

- a. Upon receiving Notice to Proceed, the selected contractor shall have **270 calendar days** to construct the project and achieve substantial completion. Substantial completion for this project includes the following items:
 - i. Preliminary Punchlist walk-through with the Town performed;
- b. After substantial completion is reached, the contractor shall have **an additional 20 calendar days** to achieve 100% final completion. Final completion for this project shall include:
 - i. Punchlist items completed and approved by the Town;
 - ii. Site clean-up;
 - iii. Submittal of Record Drawings; and
 - iv. Execution of Maintenance Bond.

J. PREPARATION OF PROPOSALS: Prices quoted shall include all items of cost, expense, taxes, fees and charges incurred by, or arising out of, the performance of the work to be performed under the Contract. Proposals shall be submitted in duplicate and shall be signed in ink. Any proposal on other than the required form will be considered informal and may be rejected. Erasures or other changes in a proposal must be explained or noted over the initials of the bidder. Proposals containing any conditions, omissions, unexplained erasures and alterations, or irregularities of any kind may be rejected as informal. The prices should be expressed in words and figures or they may be deemed informal and may be rejected. In case of discrepancy between the price written in the proposal and that given in the figures, the price in writing will be considered as the proposal. In the case of a discrepancy between a unit price and its extension, the unit price will govern. Failure to submit all requested information will make a proposal irregular and subject to rejection. Proposals shall be signed with name typed or printed below signature, and, if a partnership, give full name of all partners. Where bidder is a corporation, proposals must be signed with the legal name of the corporation followed by the name of the state of incorporation and the legal signature of an officer authorized to bind the corporation to a contract.

NOTE: AN ELECTRONIC SPREADSHEET IS POSTED ON CIVCAST FOR CONTRACTORS CONVENIENCE TITLED "BID SCHEDULE BID 22-75". THIS SPREADSHEET MAY BE USED IN LIEU OF THE MANUAL HANDWRITTEN PROPOSAL FORM IN THE SPECIFICATIONS AND SHALL BE ATTACHED TO THE PROPOSAL AND MADE PART OF THE CONTRACT DOCUMENTS. USING THE SPREADSHEET OPTION SHALL NOT AMEND OR MODIFY ANY WORDING IN THE PROPOSAL FORM OR THE PLANS AND THE CONTRACTOR SHALL BE RESPONSIBLE FOR CONFIRMING THAT THE SPREADSHEET ADEQUATELY CONVEYS THEIR PROPOSAL.

SUBMITTAL OF PROPOSALS: Sealed proposals will be received at the time, date and place stated in the Advertisement for Bids. Proposals shall be made on unaltered Proposal Forms furnished by the Town of Addison. Bidders shall submit proposals in an opaque, sealed envelope addressed to the Owner and plainly mark on the outside of the envelope the name

and address of the bidder. The envelopes shall also be marked with the following project description:

PUBLIC WORKS AND ENGINEERING SERVICES BID NUMBER 22-75

**ADDISON RAWHIDE CREEK BASIN DRAINAGE AND ADA IMPROVEMENTS FROM
BROOKWOOD LN TO WATERSIDE CT**

The Bid Bond must be completed and signed by each bidder and submitted with the proposal. Submit Proposals by mail or in person prior to the time for receiving proposals set forth in the Advertisement for Bids issued by the Town.

Electronic bidding on www.civcastusa.com will not be considered for this project. The Town of Addison uses www.civcastusa.com to distribute bids and proposals. There will be NO COST to the contractor for standard bids or proposals. Bid number 22-75 is considered a standard proposal. For Cooperative Bids and Reverse Auctions ONLY, the successful contractor/supplier agrees to pay www.civcastusa.com a transaction fee of one percent (1%) of the total amount of all contracts for goods and/or services. Cooperative Bids and Reverse Auctions will be clearly marked on the bid documents. To assure that all contractors/suppliers are treated fairly, the fee will be payable whether the bid/proposal is submitted electronically, or by paper means. Refer to www.civcastusa.com for further information.

- K. MODIFICATION AND WITHDRAWAL OF PROPOSALS:** Prior to the time set for proposal opening, proposals may be withdrawn or modified. Proposals may be modified only on the official bid form and must be signed by a person legally empowered to bind the bidder. No bidder shall modify, withdraw, or cancel his proposal or any part thereof for sixty (60) calendar days after the time agreed upon for the receipt of proposals.
- L. DISQUALIFICATION:** The Owner reserves the right to disqualify proposals, before or after the opening, upon evidence of collusion with intent to defraud or other illegal practices relating to this proposal upon the part of the bidder.
- M. SUBMISSION OF POST-PROPOSAL INFORMATION:** Upon notification of acceptance, the selected bidder shall, within twenty-four (24) hours, submit the following:
1. A designation of the portions of the Work proposed to be performed by the bidder with his own force.
 2. A list of names of the Subcontractors or other persons or organizations, including those who are to furnish materials and equipment fabricated to a special design proposed for such portions of the Work as may be designated in the Bidding Documents or as may be requested by the Town of Addison. The bidder will be required to establish to the satisfaction of the Owner the reliability and responsibility of the proposed Subcontractors and suppliers to furnish and perform the Work.
 3. Other information as required.
- N. AWARD:** The Owner reserves the right to accept any or to reject any proposals without compensation to bidders and to waive irregularities and informalities. The Town of Addison

Public Works & Engineering Services Department, in making its recommendation, will consider the following elements:

1. Whether the bidder is a contractor with experience in the type of work involved.
2. Whether the bidder has adequate plant, equipment and personnel to perform the work properly and expeditiously.
3. Whether the bidder has a suitable financial status and reputation for meeting obligations incident to work of the kind specified.
4. Whether the bidder has complied with the terms and conditions.

Alternate items may or may not be awarded. Addition or deletion of other items or schedules will be governed by the *Standard Specifications for Public Works Construction – North Central Texas, November 2017, 5th Edition*, (Latest Version) (hereinafter called SSPWC) Item 104.2 "Change or Modification of Contract".

- O. EXECUTION OF THE CONTRACT:** The successful bidder will be required to enter into a contract with the Owner within ten (10) days of notice by the Owner that his proposal has been accepted. Failure to enter into a contract within the established time limit shall be considered grounds for forfeiture of the bid bond.
- P. CONSTRUCTION SCHEDULE:** It is the Owner's desire to have the project completed and operational in as short a time as possible. The number of calendar days for completion of the project will begin with the date specified in the Notice to Proceed. The Notice to Proceed will be issued in a manner to facilitate a smooth construction of the project. The Contractor shall begin construction within ten (10) calendar days of the issuance of the Notice to Proceed.
- Q. COST PLUS TIME BIDDING:** N/A
- R. FORM OF CONTRACT:** The contract for the construction of the project will be drawn up by the Owner. A sample form of agreement is included in the Contract Agreement Section.
- S. BONDS:** A Performance Bond, a Labor and Material Payment Bond and a Maintenance Bond will be required by the Owner. The Performance Bond and Payment Bond shall name the Town of Addison, and others as directed by the Town, as joint obligees. Sample forms have been included in the Performance Bond, Payment Bond, and Maintenance Bond sections. (Contractor shall confirm the legal names of obligees prior to execution of Bonds.)
- T. BID SECURITY:** Proposals shall be accompanied by a bid bond in an amount not less than five percent (5%) of the total maximum bid from a reliable surety company licensed by the State of Texas to act as a Surety and be listed on the current U.S. Treasury Listing of Approved Sureties, or a Binder of Insurance executed by a surety company licensed by the State of Texas to act as a surety or its authorized agent as a guarantee that the bidder will enter into a contract and execute a Performance Bond and Payment Bond within ten (10) days after notice of award of contract to him.
- U. RESOLUTIONS:** If the bidder is a corporation, a copy of the resolution empowering the person submitting the proposal to bind the bidder must be included with the proposal.

- V. CONSTRUCTION STAKING:** Construction staking and re-staking will not be provided by the Owner. Benchmarks and Horizontal Control are shown on the plans. There is no separate bid item for staking, therefore, the contractor must include value for staking in the various bid items as subsidiary to the contract. Any staking or re-staking that is required shall be the responsibility of the Contractor and shall be at no cost to the Owner.
- W. FINAL PAYMENT:** The general provisions for Final Payment shall be as stated in Item 109.5.4 of the SSPWC including all Amendments and Additions. Prior to final payment the Contractor shall provide the Owner with the following items:
1. A Contractor's Affidavit of Bills Paid in accordance with Section BP.
 2. A Consent of Surety Company to Final Payment.
 3. A complete set of record plans which indicate all construction variations from the original construction documents in accordance with the Special Provisions.
 4. A Two (2) years Maintenance Bond in accordance with Section MB.
 5. Acknowledgement that the project has been reviewed and accepted by TDLR.
- X. PREVAILING WAGE RATES:** Wage rates paid on this project shall not be less than specified in the schedule of general prevailing rates of per diem wages as attached in the Special Provisions.
- Y. PRIORITY OF CONTRACT DOCUMENTS:** In case of conflict between contract documents, priority of interpretation shall be in the following order: signed agreement; performance and payment bonds; proposal; special provisions (or conditions); technical specifications; general provisions; advertisement for bids; project drawings; *Standard Specifications for Construction and Maintenance of Highways, Streets, and Bridges* adopted by the Texas Department of Transportation June 1, 2004; Standard Specifications for Public Works Construction (NCTCOG, October 2017),(Latest Version); Town of Addison Standard Drawings. This priority list shall take precedence over Item 105.1.1 of the SSPWC.

Information and Instruction Form

RESPONSES THAT DO NOT CONTAIN THIS COMPLETED FORM MAY NOT BE COMPLIANT

Section I Company Profile

Name of Business:

Business Address:

Contact Name:

Phone#:

Fax#:

Email:

Name(s) Title of Authorized Company Officers:

Federal ID #: W-9 Form: A W-9 form will be required from the successful bidder.

DUN #:

Remit Address: If different than your physical address:

Section II Instructions to Bidders

Electronic Bids: The Town of Addison uses Civcast to distribute and receive bids and proposals. There will be **NO COST** to the Contractor/Supplier for Standard bids or proposals. For **Cooperative Bids and Reverse Auctions ONLY**, the successful contractor/supplier agrees to pay Civcast a transaction fee of one percent (1%) of the total amount of all contracts for goods and/or services. **Cooperative Bids and Reverse Auctions** will be clearly marked on the bid documents. To assure that all contractors/suppliers are treated fairly, the fee will be payable whether the bid/proposal is submitted electronically, or by paper means. Refer to www.civcastusa.com for further information.

Contractor/Supplier Responsibility: It is the contractor/suppliers responsibility to check for any addenda or questions and answers that might have been issued before proposal closing date and time. Contractors/Suppliers

ADDENDUM NO. 1 - VOID PREVIOUS AND REPLACE WITH THIS SHEET

will be notified of any addenda and Q&A if they are on the invited list, they view the proposal, or add themselves to the watch list.

Acknowledgement of Addenda: #1 #2 #3 #4 #5

Delivery of Proposals: For delivery of paper proposals our physical address is:

Town of Addison

5350 Beltline Road

Dallas, TX 75254

Attn: Purchasing Department

Contractor/Supplier Employees: No Contractor/Supplier employee shall have a direct or indirect financial interest in any contract with the town, or be directly or indirectly financially interested in the sale of land, materials, supplies or services to the town.

Deliveries: All deliveries will be F.O.B. Town of Addison. All Transportation Charges paid by the contractor/supplier to Destination.

Payment Terms: A Prompt Payment Discount of % is offered for Payment Made Within Days of Acceptance of Goods or Services. If Prompt Payments are not offered or accepted, payments shall be made 30 days after receipt and acceptance of goods or services or after the date of receipt of the invoice whichever is later.

Delivery Dates: Delivery Dates are to be specified in Calendar Days from the Date of Order.

Bid Prices: Pre-Award bid prices shall remain Firm and Irrevocable for a Period of _____ Days.

Exceptions: Contractor/Supplier does not take Exception to Bid Specifications or Other Requirements of this Solicitation. If neither exceptions box is checked, default shall be "No Exceptions"

Contractor/Supplier take the following Exception(s) to the Bid Specifications or Other Requirements of this Solicitation (Explain in Detail). If box checked but no exceptions are listed, default shall be "No Exceptions"

Historically Underutilized Business (HUB): It is the policy of the Town of Addison to involve HUBs in the procurement of goods, equipment, services and construction projects. Prime Contractors/Suppliers are encouraged to provide HUBs the opportunity to compete for sub-contracting and other procurement opportunities. A listing of HUBs in this area may be accessed at the following State of Texas Website.
<http://www.window.state.tx.us/procurement/cmb/cmbhub.html>.

HUB Owned Business Yes No Include a current copy of your HUB certification with your response or insert Certification number _____ and expire date _____.

ADDENDUM NO. 1 - VOID PREVIOUS AND REPLACE WITH THIS SHEET

Other Government Entities: Would bidder be willing to allow other local governmental entities to participate in this contract, if awarded under the same Terms and Conditions? Yes No

Bid Bond: Is Bid Bond attached if applicable? Yes No

Termination: The town at any time after issuance of this agreement, by 30 days written notice, has the absolute right to terminate this agreement for cause or convenience. Cause shall be the contractor/supplier's refusal or failure to satisfactorily perform or complete the work within the time specified, or failure to meet the specifications, quantities, quality and/or other requirements specified in the contract/purchase order. In such case the supplier shall be liable for any damages suffered by the town. If the agreement is terminated for convenience, the supplier has no further obligation under the agreement. Payment shall be made to cover the cost of material and work in process or "consigned" to the town as of the effective date of the termination.

Bidder Compliance: Bidder agrees to comply with all conditions contained in this Information and Instruction Form and the additional terms and conditions and specifications included in this request. The undersigned hereby agrees to furnish and deliver the articles or services as specified at the prices and terms herein stated and in strict accordance with the specifications and conditions, all of which are made a part of your offer. Your offer is not subject to withdrawal after the award is made.

The Town of Addison reserves the right to reject all or part of the offer and to accept the offer considered most advantageous to the town by item or total proposal.

The Town of Addison will award to the lowest responsible bidder or to the bidder who provides goods or services at the best value for the Town.

I hereby certify that all of the information provided in sections I and II are true and accurate to the best of my knowledge.

Signature: Date:

Title:

Signature certifies no changes have been made to the content of this solicitation as provided by the Town of Addison.

10/17/17

**TOWN OF ADDISON
 ADDISON RAWHIDE CREEK BASIN DRAINAGE AND ADA IMPROVEMENTS
 FROM BROOKWOOD LN TO WATERSIDE CT
 PROJECT # 2022-01C
 BID NO. 22-75
 UNIT PRICES**

ITEM NO.	SPEC. NO.	DESCRIPTION	UNIT	ESTIMATED QUANTITY	UNIT PRICE	BID AMOUNT
BASE BID						
48		Irrigation (Replace Sprinkler Heads)	EA	1		
49		Standard Town Bollard	EA	5		
50		Bench	EA	2		
51		Trash Receptacle	EA	1		
52		Pet Waste Station	EA	1		
53		Town Standard Trail Signage	AL	1	\$3,500.00	\$3,500.00
54		Steel Edging	LF	355		
55		Wrought Iron Gate (4' W x 4' H)	EA	2		
56		Canopy Tree	EA	2		
57		Ornamental Tree	EA	3		
58		5 Gallon Shrub	EA	150		
59		3 Gallon Shrub	EA	16		
60		1 Gallon Shrub	EA	2,171		
61		Soil Prep/Mulch	SF	8,860		
62		Irrigation	SF	8,860		
TOTAL (BASE BID) =						\$166,500.00

- NOTES:
1. All items, labor, materials, equipment, facilities, incidentals and work required for construction of the project are to be provided and installed by the Contractor as part of the project and payment for the cost of such shall be included in the price bid for the construction of the project.
 2. Prices must be shown in words and figures for each item listed in the Proposal. In the event of discrepancy, the words shall control.
 3. Materials, which are “tax exempt”, are those items which are physically incorporated into the facilities constructed for the Town of Addison, as set forth in the Special Provisions. Materials include, but are not limited to purchased items such as water pipe, sanitary sewer pipe, storm drain pipe, etc.

Services, which are “not tax exempt”, are those items which are used by the Contractor but are not physically incorporated into the Town of Addison’s facility and/or items which are consumed by construction, as set forth in the Special Provisions. Services include, but are not limited to, items such as supplies, tools, skill and labor, the purchase, rental or lease of equipment, etc.

Name of Person Signing Proposal

Signature of Person Signing Proposal

Address

Telephone No.

Fax No.

T.I.N. (Tax Identification or Employer’s Number)



Town of Addison
GENERAL TERMS AND CONDITIONS

By submitting an Offer in response to the Solicitation, the Contractor/Seller (hereafter called Seller) agrees the Contract/Purchase Order shall be governed by the following terms and conditions for goods and services.

1. Applicability: These General Terms and Conditions and the Terms and Conditions, Specifications, Drawings and other requirements included in the Town of Addison's Request for Proposal (collectively, "Terms and Conditions") are applicable to Contracts/Purchase Orders issued by the Town of Addison (hereinafter referred to as the "Town" or "Buyer") and the Seller (herein after referred to as the "Seller"). Any deviations must be in writing and signed by a representative of the Town's Purchasing Department and the Seller. No terms and conditions contained in the Seller's Proposal, Invoice or Statement shall modify the Terms and Conditions. If there is a conflict between the Terms and Conditions and Seller's response to the Town's request for bids or proposals documents (including the provisions of the Seller's form of contract/purchase order), the Terms and Conditions will take precedence and control.
2. Official Solicitation Notification: The Town utilizes the following for official notifications of solicitation opportunities: www.civcastusa.com and the Dallas Morning News of Dallas County. These are the only forms of notification authorized by the Town for notifications of solicitation opportunities. The Town is not responsible for receipt of notifications or information from any source other than those listed. It shall be the Seller's responsibility to verify the validity of all solicitation information received from any source other than the Town. There will be NO COST to the Seller for using Civcast to respond to Town of Addison solicitations.
3. Seller to Package Goods: Seller shall package goods in accordance with good commercial practice. Each shipping container, shall be clearly and permanently marked as follows: (a) Seller's name and address; (b) consignee's name, address and purchase order or purchase change order number; (c) container number and total number of containers, e.g., "box 1 of 4 boxes"; and (d) number of the container bearing the packing slip. Seller shall bear cost of packaging unless otherwise provided and agreed to in writing by Buyer. Goods shall be suitably packed to secure lowest transportation costs and to conform to requirements of common carriers and any applicable specifications. Town's count or weight shall be final and conclusive on shipments not accompanied by packing list. Unless otherwise stated in the Town's solicitation, all goods will be new, not used, rebuilt, reconditioned or recycled, will be in first class condition, and will be in containers suitable for site.
4. Shipment Under Reservation Prohibited: Seller is not authorized to ship the goods under reservation and no tender of a bill of lading will operate as a tender of goods.
5. Title and Risk of Loss: Title and risk of loss of the goods will not pass to the Town until the Town actually receives, takes possession of, and inspects and accepts the goods at the point or points of delivery.

6. Delivery Terms and Transportation Charges: Goods shall be shipped F.O.B. point of delivery; prices bid and quoted shall be F.O.B. point of delivery, and shall include all freight, delivery and packaging costs. Town shall have the right to designate what method of transportation shall be used to ship the goods. Town assumes and shall have no liability for goods damaged while in transit and or delivered in a damaged condition or that otherwise don't conform to the Terms and Conditions. Seller shall be responsible for and handle all claims with carriers, and in case of damaged or non-conforming goods shall ship replacement goods immediately upon notification by the Town of the same, and the Town may return such damaged or non-conforming goods at Seller's sole cost and expense, including costs and expense for freight, delivery, packaging, and shipping.

7. Right of Inspection and Rejection; Backorders: The Town shall have the right, and expressly reserves all rights under law, including, but not limited to the Uniform Commercial Code, to inspect the goods at delivery before accepting them, and to reject defective or non-conforming goods. Backorders delayed beyond a reasonable period of time, as determined by the Town Purchasing Manager, may be cancelled by the Town without liability of any kind whatsoever, and payment will not be made for such cancellations.

8. Acceptance of Incomplete or Non-Conforming Goods: If, instead of requiring immediate correction or removal and replacement of defective or non-conforming goods, Town prefers to accept such goods, Town may do so. Seller shall pay all claims, costs, losses and damages attributable to Town's evaluation of and determination to accept such defective or non-conforming deliverables. If any such acceptance occurs prior to final payment, Town may deduct such amounts as are necessary to compensate Town for the diminished value of the defective or non-conforming deliverables. If the acceptance occurs after final payment, such amount will be refunded to Town by Seller.

9. Substitution: Every delivery of goods by the Seller must comply with all provisions of this proposal including the specifications, delivery schedule, quantity and quality, and the Terms and Conditions. Any delivery which does not conform to the Buyer's requirements shall constitute a breach of contract. Seller does not have authorization to make or tender substitute goods unless it is agreed to in writing by the Buyer and signed by an authorized representative of Buyer.

10. Payment:

(a) All proper invoices received by the Town will be paid within thirty (30) days of the Town's receipt and acceptance of the goods or of the invoice, whichever is later, unless other terms are specified on the face of the purchase order in the original printing. If payment is not timely made, interest shall accrue on the unpaid balance at the lesser of one percent per month or the maximum lawful rate; except, if payment is not timely made for a reason for which the Town may withhold payment hereunder, interest shall not accrue until ten (10) days after the grounds for withholding payment have been resolved.

(b) If partial shipments or deliveries are authorized by the Town, Seller will be paid for the partial shipment or delivery, as stated above, provided that the invoice matches the shipment or delivery.

(c) The Town may withhold or set off the entire payment or part of any payment otherwise due Seller to such extent as may be necessary on account of: (i) delivery of defective or non-conforming goods by Seller, or (ii) failure of the Seller to submit proper invoices with all required attachments and supporting documentation, or (iii) failure of Seller to deliver quantity of goods ordered (payment will be made for actual quantities delivered).

(d) The Town's payment obligations are payable only and solely from funds appropriated, budgeted, and available for the purpose of this purchase. The absence of appropriated and budgeted or other lawfully available funds shall render the Contract/Purchase Order null and void to the extent funds are not appropriated and budgeted or available and any goods delivered but unpaid shall be returned to Seller. The Town shall provide the Seller written notice of the failure of the Town to make an adequate appropriation and budget for any fiscal year to pay the amounts due under the Contract/Purchase Order, or the reduction of any appropriation to an amount insufficient to permit the Town to pay its obligations under the Contract/Purchase Order.

11. Invoicing: Send ORIGINAL INVOICE to address indicated on the purchase order. If invoice is subject to cash discounts the discount period will begin on the day invoices are received. So that proper cash discount may be computed, invoice should show amount of freight as a separate item, if applicable; otherwise, cash discount will be computed on total amount of invoice.

12. Taxes - Exemption: All quotations are required to be submitted LESS Federal Excise and State Sales Taxes. Tax Exemption Certificate will be provided by the Town for the successful Seller

13. Warranty - Price:

(a) Seller warrants the prices quoted in its proposal are no higher than Seller's current prices on orders by others for like goods under similar terms of purchase.

(b) Seller certifies that the prices in Seller's proposal have been arrived at independently without consultation, communication, or agreement for the purpose of restricting competition, as to any matter relating to such fees with any other firm or with any competitor.

(c) In the event of any breach of this warranty, the prices of the items will be reduced to Seller's current prices on orders by others, or in the alternative, the Town may cancel this Contract/Purchase Order without liability to Seller of any kind whatsoever. In addition to any other remedy available, the Town may deduct from any amounts owed to Seller, or otherwise recover, any amounts paid for items in excess of Seller's current prices on orders by others for like goods under similar terms of purchase.

14. Warranty – Title: Without limiting any provision of law, Seller warrants that it has good and indefeasible title to all goods furnished hereunder, and that the goods are free and clear of all liens, claims, security interests and encumbrances. **Seller shall indemnify and hold the Town harmless from and against all adverse title claims to the goods.**

30. Competitive Pricing: It is the intent of the Town to consider Interlocal Cooperative Agreements and State/Federal contracts in determining the best value for the Town.
31. Interlocal Agreement: Successful bidder (Seller) agrees to extend prices for the goods and/or services to be provided by Seller described in this Contract/Purchase Order to all entities that have entered into or will enter into joint purchasing interlocal cooperation agreements with the Town. The Town is a participating member of several interlocal cooperative purchasing agreements. As such, the Town has executed interlocal agreements, as permitted by law, including under Chapter 791 of the Texas Government Code, with certain other political subdivisions, authorizing participation in a cooperative purchasing program. The successful bidder (Seller) may be asked by the Town to provide products/services based upon the bid price to any other participant to a cooperative purchasing agreement, and the Seller agrees to do so (such provision will be pursuant to an agreement between Seller and such other participant, and the Town will have no liability or responsibility in connection therewith).
32. Right to Audit: The city shall have the right to examine and audit after reasonable notice any and all books and records, in any form or format whatsoever (including electronic), of Seller that may relate to this Contract/Purchase Order including, without limitation, the performance of Seller, its employees, agents, and subcontractors. Such books and records will be maintained in accordance with generally accepted accounting principles and shall, upon request and at the Town's request, be made available at a location designated by the Town. Seller shall, except for copying costs, otherwise bear all costs of producing such records for examination and copying by the Town. Unless otherwise agreed by the Town, such books and records must be made available to the Town within five business days after the Seller's receipt of a written notice from the Town requesting the same. The provisions of this paragraph shall survive the termination of this agreement. Seller shall retain all such books and records for a period of three (3) years after final payment on this Contract/Purchase Order or until all audit and litigation matters that the Town has brought to the attention of the Seller are resolved, whichever is longer. The Seller agrees to refund to the Town any overpayments disclosed by any such audit. The Seller shall include a similar audit right on behalf of the Town in all subcontractor agreements entered into in connection with this Contract/Purchase Order.
33. Correspondence: The Bid number must appear on all correspondence and inquiries pertaining to the Request for Proposal or to quotes. The Purchase Order number must appear on all invoices or other correspondence relating to the Contract/Purchase Order.
34. Easement Permission: The contractor shall not enter or use private property except as allowed by easements shown on the contract documents or if the contractor obtains specific written permission from the property owner.
35. Alternates - Samples: If bidding on other than the item solicited by the Town, Seller's proposal must identify the item's Trade Name, Manufacturer's Name and/or Catalog Number, and certify the item offered is equivalent to the item solicited by the Town. Descriptive literature must be submitted with alternate brands. Samples shall be furnished free of expense to the Town and if requested, may be returned at bidder's expense.

36. Error - Quantity: Proposals must be submitted in units of quantity specified, extended, and totaled. In the event of discrepancies in extension, the unit prices shall govern.
37. Acceptance: The right is reserved to the Town to accept or reject all or part of the proposal, and to accept the offer considered most advantageous to the Town by line item or total proposal.
38. Term Contracts: Except as otherwise provided herein, prices must remain firm for the entire Contract/Purchase Order period, including any periods of extension or renewal. At the time of any renewal or extension of the Contract/Purchase Order, the Town or the Seller may request a price adjustment based upon the economy. All requests for a price adjustment must include detailed documentation and rationale to support the requested adjustment. The party to whom a request for price adjustment is made may, in its sole discretion, accept or reject the request. Any price adjustment must be mutually agreed upon in writing by the parties, and shall be effective for the applicable renewal term.
39. Term Contract Quantities: The quantities (if any) in the request for proposal are estimated requirements and the Town reserves the right to increase or decrease the quantities or cancel any item to be furnished. The successful bidder (Seller) shall have no claim against the Town for anticipated profits for quantities diminished or deleted.
40. Term Contract Shipments: The Seller will make shipments under this Contract/Purchase Order only when requested and only in the quantities requested. Seller shall comply with minimum shipments or standard packaging requirements (if any) included in the Contract/Purchase Order.
41. Contract Renewal Options: In the event a clause for option to renew for an additional period is included in the request for proposal, all renewals will be based solely upon the option and agreement between the Town and the Seller. Either party dissenting will terminate the Contract/Purchase Order in accordance with its initial specified term.
42. Electronic Signature – Uniform Electronic Transactions Act: The Town adopts Texas Business and Commerce Code Chapter 322, Uniform Electronic Transactions Act, allowing individuals, companies, and governmental entities to lawfully use and rely on electronic signatures.
43. Funding Out Clause: This Contract/Purchase Order may be terminated by the Town without notice and without penalty or liability in the event that (1) the Town lacks sufficient funds for this Contract/Purchase Order; (2) funds for this Contract/Purchase Order are not appropriated and/or budgeted by the City Council of the Town; and (3) funds for this Contract/Purchase Order that are or were to be provided by grant or through a third party are withheld, denied or are otherwise not available to the Town.
44. Dispute Resolution: Pursuant to subchapter I, Chapter 271, Texas Local Government Code, Seller agrees that, prior to instituting any lawsuit or other proceeding arising from any dispute or claim of breach under this Contract/Purchase Order (a “Claim”), the parties will first attempt to resolve the Claim by taking the following steps: (i) A written notice substantially describing the factual and legal basis of the Claim shall be delivered by the Seller to the Town

57. Response Contractual Obligation; Waiver: This response, submitted documents, and any negotiations, when properly accepted by the Town, shall constitute a contract equally binding between the successful Seller and the Town. No different or additional terms will become part of this Contract/Purchase Order except as properly executed in an addendum or change order. **By submitting a proposal, Seller waives any claim it has or may have against the Town, its officials, officers, employees, and agents, arising out of or in connection with the administration, evaluation, or recommendation of any proposal, acceptance or rejection of any proposal, and the award of a contract.**

58. No Waiver of Immunity. Notwithstanding any other of this Contract/Purchase Order, nothing in this Contract/Purchase Order shall or may be deemed to be, or shall or may be construed to be, a waiver or relinquishment of any immunity, defense, or tort limitation to which the Town, its officials, officers, employees, representatives, and agents are or may be entitled, including, without limitation, any waiver of immunity to suit.

59. No Boycotting Israel. The entity contract with the Town of Addison does not boycott Israel and will not boycott Israel during the term of the contract. Reference HB 89 as it relates to Chapter 2270 of the Texas Government Code. Boycott Israel means refusing to deal with, terminating business activities with, or otherwise taking any action that is intended to penalize, inflict economic harm on, or limit commercial relations specifically with Israel or with a person or entity doing business in Israel or in an Israeli-controlled territory, but does not include an action made for ordinary business purposes.

PROJECT: ADDISON RAWHIDE CREEK BASIN DRAINAGE AND ADA IMPROVEMENTS FROM BROOKWOOD DR TO WATERSIDE CT

Portions of TxDOT standards and specifications, latest editions, shall be incorporated into this contract by specific reference in the contract plans and specifications. In the event of conflict with other documents, TxDOT standards and specifications shall govern for construction materials and methods. In the event of conflict with other documents, Town of Addison contract documents shall govern for contract procedures and measurement and payment.

5. **SUBSURFACE INVESTIGATION:** Subsurface exploration to ascertain the nature of soils, including the amount of rock, if any, is the responsibility of any and all prospective Bidders. It shall be the responsibility of the Bidders to make such subsurface investigations as he deems necessary to determine the nature of the material to be encountered. Some preliminary subsurface exploration has been performed by the Town of Addison and the Engineer, and is provided to the Contractor in the Contract Documents. This information is provided only as preliminary and all proposals shall be based on information obtained by the Contractor. The Town of Addison and the Engineer disclaim any responsibility for the accuracy, true location and extent of the soils information that has been prepared by others. They further disclaim responsibility for interpretation of that data by Bidders, as in projecting soil bearing values, rock profiles, soils stability and the presence, level and extent of underground water.
6. **HISTORICAL, SCIENTIFIC AND ARCHAEOLOGICAL DISCOVERIES:** Contractor shall immediately give an oral and written report to the Town of Addison of the discovery of any articles of historical, scientific, or archaeological significance. Contractor shall take all necessary steps to preserve the article and shall cease operations, which would affect the find until otherwise directed by the Town of Addison but continue with all other unaffected operations. The future operations of Contractor with respect to the discovery, including disposition of the articles, shall be decided by the Town of Addison. The Town of Addison shall have sole and exclusive title to any discovered articles.

The Town of Addison shall investigate the site conditions promptly after receiving the notice. If the conditions do materially so differ and cause an increase or decrease in Contractor's cost of, or the time required for performing any part of the work under the Contract, whether or not changed as a result of conditions, an equitable adjustment will be made and the Contract modified in writing accordingly.

No request by Contractor for an equitable adjustment to the Contract under this Section shall be allowed unless Contractor has given the written notice required. No request by Contractor for an equitable adjustment of the Contract for differing site conditions will be allowed or shall be made after final payment under the Contract.

ENVIRONMENTAL REQUIREMENTS: In addition to requirements set forth in other sections of the Contract, including the Plans and Specifications, Contractor shall ensure that the requirements of this Section are fulfilled and incorporated into its procedures and processes as well as those of any Subcontractors. All materials utilized by Contractor on the Project shall comply with all applicable local, state and federal laws and regulations.

PROJECT: ADDISON RAWHIDE CREEK BASIN DRAINAGE AND ADA IMPROVEMENTS FROM BROOKWOOD DR TO WATERSIDE CT

- 16. PREPARATION OF STORM WATER POLLUTION PREVENTION PLAN:** A Storm Water Pollution Prevention Plan (SW3P) will be required for this project, the area disturbed on this project during construction exceed 1 acre.
- This specification is not all inclusive of the requirements for an SW3P. The Contractor shall comply with all requirements of the TCEQ TPDES permit and the local authorities' storm water ordinance and/or regulations.
- 17. ADDENDA:** Bidders desiring further information, or interpretation of the Plans and Specifications, must make written request for such information to the Engineer (not later than four (4) working days prior to the date set for the Proposal opening. The ability to ask questions will close at **5:00 PM, Wednesday, August 24, 2022**. Answers to all such requests will be issued in the form of Addenda and a copy of such Addenda will be released through www.civcastusa.com. It will be the responsibility of each person who has been issued as set of Bidding Documents to secure all Addenda from www.civcastusa.com. Addenda will be bound with and made a part of the Contract Documents. No other explanation or interpretation will be considered official or binding. Should a Bidder find discrepancies in, or omissions from, the Plans, Specifications or Contract Documents, or should it be in doubt as to their meaning, it shall at once notify the Engineer in writing in order that a written addendum may be sent to all Bidders.
- 18. PAY ITEMS:** Pay items provided are intended to be all-inclusive of the Work required on this Project. Work required by the Plans or Specifications but not provided with a specific pay item shall be considered incidental to other items of Work. Final payment to the construction Contractor shall not be made until all Work has been finally completed and verified in accordance with the construction contract, Plans and Specifications and have been finally accepted by the Town of Addison.
- 19. QUANTITIES:** The quantities in the Bid Items are approximate and may represent quantities in excess of those actually installed. Final Payment will be based on the actual quantities installed and paid in accordance with the applicable Specifications.
- 20. BID ITEMS / REFERENCE SPECIFICATIONS:** The requirements of NCTCOG standard specifications for Public Works construction 5th edition dates 2017 or latest edition, and TxDOT standard specifications for construction and maintenance of highways, streets, and bridges , dated 2004 or latest edition, shall apply as described.
- 21. BID ITEMS DESCRIPTIONS:**

SECTION A – GENERAL**Bid Item No. 1 - MOBILIZATION (5% MAX)**

This item shall cover the lump sum cost for all charges for labor and for moving supplies, construction equipment and materials to the project site at the beginning of the project and for removing the same equipment and related supplies upon completion of the project, and for site cleanup. **See Special Provisions No. 27 for details for payment for this line Item.**

PROJECT: ADDISON RAWHIDE CREEK BASIN DRAINAGE AND ADA IMPROVEMENTS FROM BROOKWOOD DR TO WATERSIDE CT

SECTION E – LANDSCAPING

Bid Item No. 45 – BLOCK SOD

This work includes the furnishing and installation of block sod as shown on the plans and in accordance with the specifications, details and notes. These pay items shall be inclusive of all items necessary to complete the installation.

Measurement and payment shall be made on the basis of the price per bid square yard (SY) and shall be total compensation for furnishing all materials, tools, equipment, labor, and any other incidentals necessary to complete the work.

Bid Item No. 46 – TOP SOIL (4” DEPTH)

This work includes the furnishing and installation of topsoil (4” depth) as shown on the plans and in accordance with the specifications, details and notes. These pay items shall be inclusive of all items necessary to complete the installation.

Measurement and payment shall be made on the basis of the price per bid square yard (SY) and shall be total compensation for furnishing all materials, tools, equipment, labor, and any other incidentals necessary to complete the work.

Bid Item No. 47 – REMOVE TREES

This item shall consist of the removal and disposal of existing trees at the locations shown in the drawings. Existing trees shall be removed in accordance with appropriate specifications, details, and notes.

Measurement and payment shall be made on the basis of price bid per each (EA) and shall be total compensation for furnishing all materials, tools, equipment, labor, and any other incidentals necessary to complete the work.

Bid Item No. 48 – IRRIGATION (REPLACE SPRINKLER HEADS)

This item shall consist of the removal and replacement of existing sprinklers as needed throughout the project. Sprinklers will be replaced in kind or an approved equal. Sprinklers shall be replaced in accordance with appropriate specifications, details, and notes. All work is to be accomplished by or directly supervised at all times by an on-site Irrigator currently licensed by the State of Texas.

Measurement and payment shall be made on the basis of price bid per each (EA) and shall be total compensation for furnishing all materials, tools, equipment, labor, and any other incidentals necessary to complete the work.

Bid Item No. 49 – STANDARD TOWN BOLLARD

Bid Item No. 50 – BENCH

Bid Item No. 51 – TRASH RECEPTACLE

Bid Item No. 52 – PET WASTE STATION

This work includes the furnishing and installation of standard town bollard(s), bench(es), trash receptacle(s), and pet waste station(s) as shown on the plans and in accordance with the

PROJECT: ADDISON RAWHIDE CREEK BASIN DRAINAGE AND ADA IMPROVEMENTS FROM BROOKWOOD DR TO WATERSIDE CT

Town of Addison Specifications and requirements, details and notes. These pay items shall be inclusive of all items necessary to complete the installation.

Measurement and payment shall be made on the basis of the price per bid each (EA) and shall be total compensation for furnishing all materials, tools, equipment, labor, and any other incidentals necessary to complete the work.

Bid Item No. 53 – TOWN STANDARD TRAIL SIGNS

This work includes the furnishing and installation town standard trail signs as determined by Town of Addison Parks and Recreation. These pay items shall be inclusive of all items necessary to complete the installation.

Measurement and payment shall be made on the basis of price bid per allowance (AL) and shall be total compensation for furnishing all materials, tools, equipment, labor, and any other incidentals necessary to complete the work as directed by the engineer.

Bid Item No. 54 – STEEL EDGING

This work includes the furnishing and installation of steel edging as shown on the plans and in accordance with the specifications, details and notes. These pay items shall be inclusive of all items necessary to complete the installation.

Measurement and payment shall be made on the basis of the price per bid linear foot (LF) and shall be total compensation for furnishing all materials, tools, equipment, labor, and any other incidentals necessary to complete the work.

Bid Item No. 55 – WROUGHT IRON GATE (4' W X 4' H)

This work includes the furnishing and installation of wrought iron gates to provide access from Marsh Lane to Redding Trail. Location to be determined in field. These pay items shall be inclusive of all items necessary to complete the installation.

Measurement and payment shall be made on the basis of the price per bid each (EA) gate installed and shall be total compensation for furnishing all materials, tools, equipment, labor, and any other incidentals necessary to complete the work.

Bid Item No. 56 – CANOPY TREE

Bid Item No. 57 – ORNAMENTAL TREE

Bid Item No. 58 – 5 GALLON SHRUB

Bid Item No. 59 – 3 GALLON SHRUB

Bid Item No. 60 – 1 GALLON SHRUB

This work includes the furnishing and installation of canopy and ornamental trees and 1-, 3- or 5-gallon shrubs as shown on the plans and in accordance with the specifications, details and notes. These pay items shall be inclusive of all items necessary to complete the installation.

PROJECT: ADDISON RAWHIDE CREEK BASIN DRAINAGE AND ADA IMPROVEMENTS FROM BROOKWOOD DR TO WATERSIDE CT

Measurement and payment shall be made on the basis of the price per bid each (EA) and shall be total compensation for furnishing all materials, tools, equipment, labor, and any other incidentals necessary to complete the work.

Bid Item No. 61 – SOIL PREP/MULCH

This work includes the furnishing and installation of soil prep and/or mulch at locations shown on the plans and in accordance with the specifications, details and notes. These pay items shall be inclusive of all items necessary to complete the installation.

Measurement and payment shall be made on the basis of the price per bid square foot (SF) and shall be total compensation for furnishing all materials, tools, equipment, labor, and any other incidentals necessary to complete the work.

Bid Item No. 62 – IRRIGATION

This work includes the furnishing and installation of the irrigation system as shown on the plans and in accordance with the specifications, details and notes. These pay items shall be inclusive of all items necessary to complete the installation. All work is to be accomplished by or directly supervised at all times by an on-site Irrigator currently licensed by the State of Texas.

Measurement and payment shall be made on the basis of the price per bid square foot (SF) and shall be total compensation for furnishing all materials, tools, equipment, labor, and any other incidentals necessary to complete the work.

22. **SUBSIDIARY WORK:** Any and all Work specifically governed by documentary requirements for the Project, such as conditions imposed by the Plans or these Special Provisions, in which no specific item for bid has been provided for in the Proposal, shall be considered as a subsidiary item of Work, the cost of which shall be included in the various bid items in the Proposal. Costs of CCTV, permits, inspection fees, traffic control, construction staking, surface restoration and cleanup are general items of Work which fall in the category of subsidiary Work. Any repairs or replacement of items damaged during demolition or as a result of new construction will be considered subsidiary. Limits of all Work requiring repair will be determined by the Town of Addison staff or the inspector. Extreme care should be taken during all demolition and construction operations.
23. **QUALIFICATION OF PROPOSALS:** The Town of Addison reserves the right to reject any and all Proposals, to waive any and all informalities not involving price, time or changes in the Work, and the right to disregard all nonconforming, non-responsive, unbalanced, or conditional Proposals. The Town reserves the right to reject the Proposal of any Bidder if the Town believes that it would not be in the best interest of the Project to make an award to that Bidder, whether because the Proposals is not responsive or the Bidder is unqualified or of doubtful financial ability or fails to meet any other pertinent standard or criteria established by the Town. Discrepancies in the multiplication of units of Work and unit prices will be resolved in favor of the unit prices. Discrepancies between the indicated sum of any column of figures and the correct sum thereof will be resolve in favor of the correct sum.

PROJECT: ADDISON RAWHIDE CREEK BASIN DRAINAGE AND ADA IMPROVEMENTS FROM BROOKWOOD DR TO WATERSIDE CT

To be considered responsive, the apparent two lowest Bidders are required to submit the Statement of Experience per Section BQS “Bidder Qualification Statement” within 5 days.

The apparent low two Bidders will be notified by the Engineer to request the information.

AWARD AND EXECUTION OF CONTRACT: For the purpose of award, each proposal submitted shall consist of three parts whereby the correct summation of the products of the estimated quantities shown in the proposal, multiplied by their bid unit prices for the following parts:

- ADDISON RAWHIDE CREEK BASIN DRAINAGE AND ADA IMPROVEMENTS FROM BROOKWOOD DR TO WATERSIDE CT.**

Bidders must fill bid proposal for all base bids and all additive alternates. The method of Award will be based on the lowest qualified bidder for all base bids plus any combination of the additive alternates depending on the availability of funds.

The Town reserves the right to accept whichever proposal is determined to be in the best interest of the public and to reject all proposals.

All payments will be based on actual quantities and bid unit prices.

- 24. EXPLANATION OF CONTRACT TIME:** The term “Contract Time” as used in this Provision will mean the **270** calendar days (approx. 9 months) for substantial completion of the Work of the Contract from the date the Contract was executed. The term “calendar day” as used in this Article will mean every day shown on the calendar. Calendar days will be consecutively counted from commencement of Contract Time (issuance of a Notice to Proceed) regardless of weather, weekends, and holidays, suspensions of Contractor’s operations, delays or other events as described herein.

In the event of a catastrophic event (i.e., war, invasion, riot, declared state of emergency, national strike, or other situations as declared by the Town of Addison) directly and substantially affecting the Contractor’s operations on the Contract, the Contractor and the Town shall agree as to the number of calendar days to extend the Contract Time. In the event the Contractor and Town are unable to agree to the number of calendar days to extend the Contract Time, the Town shall unilaterally determine the number of calendar days to extend the Contract Time reasonably necessary and due solely to such catastrophic event and the Contractor shall have no right whatsoever to contest such determination, save and except that the Contractor establishes that the number of calendar days determined by the Town were arbitrary or without any reasonable basis.

Should the Contractor fail to complete the Contract on or before expiration of the Allowable Contract Time, as adjusted in accordance with the special provisions No. 78 of liquidated damage, the Town shall deduct from the moneys due the Contractor the Daily Value for each calendar day completion exceeds the Allowable Contract Time. The term “Allowable Contract Time” as used in this Article shall mean the Original Contract Time

PROJECT: ADDISON RAWHIDE CREEK BASIN DRAINAGE AND ADA IMPROVEMENTS FROM BROOKWOOD DR TO WATERSIDE CT

plus adjustments pursuant to the statements above. This deduction shall be the disincentive for the Contractor's failing to timely complete the Contract. **This shall be strictly enforced.**

25. **COPIES OF PLANS FURNISHED:** One (1) copy of 24" x 36" and one (1) electronic copy of the Plans shall be furnished to the successful Contractor, at no charge, for construction purposes.
26. **PRE-CONSTRUCTION CONFERENCE:** The successful Contractor, Engineer, and Town of Addison shall meet for a pre-construction conference before any of the Work begins on this Project. At this time, details of sequencing of the Work, contact individuals for each party, testing requirements, submittals, traffic control, time sensitive completion of the project and pay requests will be covered. Prior to the meeting, the Contractor shall prepare schedules showing the sequencing and progress of their Work and its effect on others. A final composite schedule will be prepared during this conference to allow an orderly sequence of Project construction.

Prior to the start of construction, Contractor shall video the construction area and property adjacent to construction in the presence of the City Inspector. The format shall be DVD. The video shall be narrated. The Contractor shall furnish the Town of Addison a copy of the video in DVD format prior to commencement of Project. This shall be subsidiary to Project.

27. **MOBILIZATION:** Mobilization and Demobilization includes the movement of all labor, equipment and supplies, establishment of facilities necessary for work, and other work and operations which must be performed and cost no directly attributable to other pay items, excluding bidding costs, which must be incurred in order to enable the Contractor to begin work on other contract items. And this item includes all work for removing all equipment and supplies and project site cleanup.

Payment

- Partial Payments of the Lump Sum bid for Mobilization shall be limited as follows:
- When 1% of the *adjusted contract amount is earned, 50% of the Mobilization Lump Sum or 5% of the total contract amount shall be paid, whichever is less. Previous payments under this item will be deducted from this amount.
- When 5% of the *adjusted contract amount is earned, 75% of the Mobilization Lump Sum or 10% of the total contract amount shall be paid, whichever is less. Previous payments under this item will be deducted from this amount.
- When 10% of the *adjusted contract amount is earned, 90% of the Mobilization Lump Sum or 25% of the total contract amount shall be paid, whichever is less. Previous payments under this item will be deducted from this amount.
- When all work under the contract is completed by the Contractor and accepted by the Town, 100% of the Mobilization Lump Sum will be paid

PROJECT: ADDISON RAWHIDE CREEK BASIN DRAINAGE AND ADA IMPROVEMENTS FROM BROOKWOOD DR TO WATERSIDE CT

28. GENERAL SEQUENCE OF CONSTRUCTION: Prior to the start of Work, the Contractor shall develop a detailed construction and sequence of construction schedule using the critical path method (CPM) and submit to the Town of Addison and Engineer for approval. The CPM shall reflect all definable features of Work and activities that shall cause minimum interference with traffic along, across and adjacent to the Project during construction. If the schedule or sequence becomes unworkable or unsatisfactory as Work proceeds, adjustments shall be made. During all phases of construction access to all existing businesses must be maintained at all times unless otherwise authorized in writing by the Town of Addison. Erosion control devices must be properly installed and maintained during all stages of construction.

1. The project schedule shall be prepared using Microsoft Project, Primavera P6 or other as approved by the OWNER. Electronic files in the scheduling software native format and PDF copies shall be included with all schedule submittals.
2. The Original Project Schedule submitted prior to construction and approved by the OWNER shall become the basis for measuring progress and evaluating whether the project is on schedule (Baseline schedule for the project). Once approved by the OWNER, the Original Project Schedule shall not be changed.
3. There shall be at a minimum one schedule Activity for each major bid item in the proposal. Many bid items will need to consist of multiple Activities.
4. The length of this project is such that many Activities or Sets of activities will be repeated for various stages of construction and segments of the roadway. Any repeated Activity must clearly identify the location and/or stage of construction.
5. The schedule must be based on clearly defined Activities, phases of construction and any project milestones. Schedule limits must be easily field verified.
6. All Activities must have Predecessor and Successor activities (except start and finish milestones). Independent or open-ended activities shall not be included.
7. The schedule must clearly identify relationship between Predecessor and Successor activities as “start-to-start”, “start-to-finish”, or “finish-to-finish”.
8. Negative lag times shall not be permitted.
9. Activities with a duration of twenty days or greater shall be broken into sub-activities. (For example, if the activity for “Install Water Line A” has a duration of 21 days, it should be divided into sub-activities such as “Install Water Line A, Sta 0+00 to 15+00”, etc.)
10. Monthly schedule updates shall include actual start and completion dates for completed and ongoing Activities. Original Project Schedule dates must be shown for tracking purposes.
11. For activities behind schedule, a Recovery Plan must be submitted detailing how project will be brought back within schedule. This may include such measures as adding work crews, leasing additional equipment, or engaging subcontractors. Fragments or copies of the revised schedule reflecting proposed changes shall be used to document proposed plan revisions and their schedule impacts. Any additional costs resulting from Recovery Plan measures shall be at the contractor’s sole expense.
12. Activity durations reflected in the original schedule cannot be reduced without a Recovery Plan description reflecting what additional resources or actions will be implemented justifying the schedule change.

PROJECT: ADDISON RAWHIDE CREEK BASIN DRAINAGE AND ADA IMPROVEMENTS FROM BROOKWOOD DR TO WATERSIDE CT

The Contractor must comply with all work area restrictions as indicated in the Plans unless specifically authorized in writing by the Town of Addison.

- 29. PROJECT REPRESENTATIVE:** The Town of Addison, the Engineer, the Contractor(s), and any applicable public utilities shall designate a single individual within their organization to act as liaison for the Project. This individual shall be aware of the day-to-day activities on the Project, have authority to make decisions binding on the party, and serve as single point for coordination of activities with the other team members. The Contractor's representative must be available to meet and discuss construction related issues on site or at the Town's offices within 20 minutes of a request during working hours and throughout the entire construction period. Upon repeated failure of attendance at requested meetings, Contractor will be required to have a Project representative on-site at all times.
- 30. COORDINATION WITH OTHERS:** In the event that other Contractors are doing Work in the same area simultaneously with this Project, the Contractor shall coordinate his proposed construction with that of the other Contractors. The Town of Addison and/or the Engineer shall mediate any disputes, and the Contractors shall comply with their decisions.
- 31. INSURANCE:** Each insurance policy that the Contractor must furnish in accordance with these contract documents shall name the Town of Addison and the Engineer as additional insured. Contractor shall include in their proposal package, a copy of their certificate of insurance showing compliance to the limits established by the Town of Addison.
- 1.0 The Contractor shall agree to furnish and maintain continuously during the period of this agreement, any renewals or extension, insurance coverage meeting all of the following requirements:
- 1.1 Commercial General Liability Insurance at minimum combined single limits of \$1,000,000 per occurrence and \$2,000,000 general aggregate for Bodily Injury and Property Damage, which coverage shall include Products/Completed Operations, and XCU Hazards. Coverage for product/completed operations must be maintained for at least two (2) years after the construction Work has been completed. Coverage must be amended to provide for an each-project aggregate limit of insurance. Contractual Liability must be included.
- 1.2 Workers Compensation Insurance at statutory limits, including employer's liability coverage at minimum limits of \$1,000,000 each occurrence-each accident, \$1,000,000 by disease-each occurrence and \$1,000,000 by disease aggregate
- 1.3 Commercial Automobile Liability Insurance at minimum combined single limits of \$1,000,000 per occurrence for bodily injury and property damage, including owned, non-owned, and hired car coverage.

PROJECT: ADDISON RAWHIDE CREEK BASIN DRAINAGE AND ADA IMPROVEMENTS FROM BROOKWOOD DR TO WATERSIDE CT

- 1.4 Umbrella Liability at minimum limits of \$1,000,000 each-occurrence \$4,000,000 aggregate with respect to primary commercial general liability, automobile liability and employer's liability policies.
 - 1.5 Any Subcontractor(s) hired by the Contractor shall maintain insurance coverage equal to that required by the Contractor. It is the responsibility of the Contractor to assure compliance with this provision. The Town accepts no responsibility arising from the conduct, or lack of conduct, of the Subcontractor.
 - 1.6 A comprehensive general liability insurance form may be used in lieu of a commercial general liability form. In this event, coverage must be written on an occurrence basis, at limits of \$1,000,000 each-occurrence, combined single limit and coverage must include a broad form comprehensive general liability endorsement, products/completed operations, XCU hazards and contractual liability.
- 2.0 With reference to the foregoing insurance requirements, Contractor shall specifically endorse applicable insurance policies as follows:
- 2.1 The Town shall be named as an additional insured with respect to general liability and automobile liability.
 - 2.2 All liability policies shall contain no cross-liability exclusions or insured versus insured restrictions.
 - 2.3 A waiver of subrogation in favor of the Town of Addison shall be contained in the workers compensation and all liability policies.
 - 2.4 All insurance policies shall be endorsed to require the insured to immediately notify the Town of Addison of any material changes in the insurance coverage.
 - 2.5 All insurance policies shall be endorsed to the effect that the Town will receive at least thirty (30) days' notice prior to cancellation or non-renewal of the insurance.
 - 2.6 All certificates shall be mailed to Town of Addison, Purchasing Dept., P.O. Box 9010, Addison, Texas 75001 or emailed to purchasing@addisontx.gov.
 - 2.7 All insurance policies, which name the Town as an additional insured, must be endorsed to read as primary coverage regardless of the application of other insurance.
 - 2.8 Required limits may be satisfied by any combination of primary and umbrella liability insurances.

PROJECT: ADDISON RAWHIDE CREEK BASIN DRAINAGE AND ADA IMPROVEMENTS FROM BROOKWOOD DR TO WATERSIDE CT

- 2.9 Contractor may maintain reasonable and customary deductibles, subject to approval by the Town.
- 3.0 All insurance shall be purchased from an insurance company who meets the following requirements:
 - 3.1 Must be issued by a carrier, which is rated “A-” VII or better by A.M. Best’s Key Rating Guide.
 - 3.2 Licensed and admitted doing business in the State of Texas and is a subscriber to the Texas Guaranty Fund.
- 4.0 All insurance must be written on forms filed with and approved by the Texas State Board of Insurance. Certificates of insurance shall be prepared and executed by the insurance company or its authorized agent and shall contain provisions representing and warranting the following:
 - 4.1 Set forth all endorsements and insurance coverages according to requirements and instruction contained herein.
 - 4.2 Shall specifically set forth the notice-of-cancellation or termination provisions to the Town.
- 5.0 Upon request, Contractor shall furnish the Town of Addison with certified copies of all insurance policies.

WORKERS’ COMPENSATION INSURANCE COVERAGE:

A. Definitions.

Certificate of Coverage (“certificate”) - A copy of a certificate of insurance, a certificate of authority to self-insure issued by the Texas Workers’ Compensation Commission (the “TWCC”), or a coverage agreement (TWCC-81, TWCC-82, TWCC-83 or TWCC-84), showing statutory workers’ compensation insurance coverage for the person’s or entity’s employees providing services on a Project, for the duration of the Project.

Duration of the Project - includes the time from the beginning of the Work on the Project until the Contractor’s/person’s Work on the Project has been completed and accepted by the governmental entity.

Persons Providing Services on the Project (“Subcontractor” in Section 406.096 of the Texas Labor Code) - includes all persons or entities performing all or part of the services the Contractor has undertaken to perform on the Project, regardless of whether that person contracted directly with the Contractor and regardless of whether that person has employees. This includes, without limitation, independent Contractors, Subcontractors, leasing companies, motor carriers, Town-operators, employees of any such entity or employees of any entity which furnishes persons

PROJECT: ADDISON RAWHIDE CREEK BASIN DRAINAGE AND ADA IMPROVEMENTS FROM BROOKWOOD DR TO WATERSIDE CT

to provide services on the Project. "Services" include, without limitation, providing, hauling, or delivering equipment or materials, or providing labor, transportation, or other service related to a Project. "Services" does not include activities unrelated to the Project, such as food/beverage vendors, office supply deliveries, and delivery of portable toilets.

- B. The Contractor shall provide coverage, based on property reporting of classification codes and payroll amounts and filing of any coverage agreement, which meets the statutory requirements of Texas Labor Code, 401.011(44) for all employees of the Contractor providing services on the Project, for the duration of the Project.
- C. The Contractor must provide a certificate of coverage to the Town of Addison prior to being awarded the contract.
- D. If the coverage period shown on the Contractor's current certificate of coverage ends during the duration of the Project, the Contractor must, prior to the end of the coverage period, file a new certificate of coverage with the Town of Addison, showing that the coverage has been extended.
- E. The Contractor shall obtain from each person providing services on the Project, and provide to the Town of Addison:
 - (1) a certificate of coverage, prior to that person beginning Work on the Project, so that the Town of Addison will have on file certificates of coverage showing coverage for all persons providing services on the Project; and,
 - (2) no later than seven days after receipt by the Contractor, a new certificate of coverage showing extension of coverage, if the coverage period shown on the current certificate of coverage ends during the duration of the Project;
- F. The Contractor shall retain all required certificates of coverage on file for the duration of the Project and for one year thereafter.
- G. The Contractor shall notify the Town of Addison in writing by certified mail or personal delivery, within 10 days after the Contractor knew or should have known, of any change that materially affects the provision of coverage of any person providing services on the Project.
- H. The Contractor shall post on each Project site a notice, in the text, form and manner prescribed by the TWCC, informing all persons providing services on the Project that they are required to be covered, and stating how a person may verify current coverage and report failure to provide coverage.
- I. The Contractor shall contractually require each person with whom it contracts to provide Services on a Project to:
 - (1) provide coverage, based on proper reporting of classification codes and payroll amounts and filing of any coverage agreements, which meets the

PROJECT: ADDISON RAWHIDE CREEK BASIN DRAINAGE AND ADA IMPROVEMENTS FROM BROOKWOOD DR TO WATERSIDE CT

- statutory requirements of Texas Labor Codes 401.011 (44) for all its employees providing services on the Project, for the duration of the Project;
- (2) provide to the Contractor, prior to that person beginning Work on the Project, a certificate of coverage showing that coverage is being provided for all employees of the person providing services on the Project, for the duration of the Project;
 - (3) provide the Contractor, prior to the end of the coverage period, a new certificate of coverage showing extension of coverage, if the coverage period shown on the current certificate of coverage ends during the duration of the Project;
 - (4) obtain from each person with whom it contracts, and provide to the Contractor;
 - a. a certificate of coverage, prior to the other person beginning Work on the Project; and,
 - b. a new certificate of coverage showing extension of the coverage period, prior to the end of the coverage period, if the coverage period shown on the current certificate of coverage ends during the duration of the Project.
 - (5) retain all required certificates of coverage on file for the duration of the Project and for one year thereafter;
 - (6) notify the Town of Addison in writing by certified mail or personal delivery, within 10 days after the person knew or should have known, of any change that materially affects the provision of coverage of any person providing services on the Project; and
 - (7) contractually require each other person with whom it contracts to perform as required by paragraphs (1) - (7) with the certificate of coverage to be provided to the person for whom they are providing services.
- J. By signing this contract or providing or causing to be provided a certificate of coverage, the Contractor is representing to the Town of Addison that all employees of the Contractor who will provide services on the Project will be covered by worker's compensation coverage for the duration of the Project, that the coverage will be based on proper reporting of classification codes and payroll amounts, and that all coverage agreements will be filed with the appropriate insurance carrier or, in the case of a self-insured, with the TWCC's Division of Self-Insurance Regulation. Providing false or misleading information may subject the Contractor to administrative penalties, criminal penalties, civil penalties or other civil actions.
- K. The Contractor's failure to comply with any of these provisions is a breach of contract by the Contractor which entitles the Town of Addison to declare the

PROJECT: ADDISON RAWHIDE CREEK BASIN DRAINAGE AND ADA IMPROVEMENTS FROM BROOKWOOD DR TO WATERSIDE CT

contract void if the Contractor does not remedy the breach within ten days after receipt of notice of breach from the Town.

The following is the form of notice of workers' compensation coverage prescribed by the TWCC. Pursuant to Section 110.110 (d) (7), this notice must be printed with a title in at least 30-point bold type, and text in at least 19-point nominal type, and shall be in both English and Spanish and any other language common to the worker population.

REQUIRED WORKERS' COMPENSATION COVERAGE

“The law requires that each person working on this site or providing services related to this construction Project must be covered by workers' compensation insurance. This includes persons providing, hauling or delivering equipment or materials, or providing labor or transportation or other service related to the Project, regardless of the identity of their employer or status as an employee.

“Call the Texas Workers' Compensation Commission (TWCC) at (512) 440-3789 to receive further information on the legal requirements for coverage, to verify whether your employer has provided the required coverage, or to report an employer's failure to provide coverage.”

32. RESOLUTION OF DISPUTES: The parties hereby covenant and agree that in the event of any controversy, dispute, or claim, of whatever nature arising out of, in connection with or in relation to the interpretation, performance or breach of this Contract, including but not limited to any claims based on contract, tort or statute, before filing a lawsuit, the parties agree to submit the matter to Alternative Dispute Resolution pursuant to the laws of the State of Texas. The parties shall select a third party arbitrator or mediator from the current list of neutrals on file with the Alternative Dispute Resolution Administrator of the Dallas County District Courts or other mutually agreeable mediator or arbitrator. All forms of Alternative Dispute Resolution may be used except binding arbitration. The proceedings shall be conducted in accordance with the laws of the State of Texas.

33. SHOP DRAWINGS: The Contractor shall provide, review, approve and submit all shop drawings, product data and samples required by the Town of Addison, the Engineer and the Contract Documents in accordance with Item 1.28 of the Standard Specifications for Public Works Construction, North Central Texas Council of Governments. The Contractor shall electronically submit shop drawing for review to Kimley-Horn, who will review, comment and forward to the Town of Addison for acceptance.

Shop drawings shall include all items to be installed in the Project, including but not limited to:

- Concrete Mix Designs
- Storm Sewer Pipe
- Sanitary Sewer Pipe/Fitting
- Traffic Control Plan
- Manholes & Vaults
- Backfill Materials
- Water Main Pipe/Fitting
- Valves & Boxes

PROJECT: ADDISON RAWHIDE CREEK BASIN DRAINAGE AND ADA IMPROVEMENTS FROM BROOKWOOD DR TO WATERSIDE CT

34. **PROJECT VIDEO:** Prior to the start of construction, Contractor shall video the construction area and property adjacent to construction in the presence of the City Inspector. The format shall be DVD. The video shall be narrated. The Contractor shall furnish the Town of Addison a copy of the video in DVD format prior to commencement of Project. This effort shall be considered as subsidiary to the various bids items for this Project (See Section 19).
35. **SAMPLES AND TESTS OF MATERIALS:** The Town of Addison shall designate and pay an independent testing laboratory to furnish testing for this Project. Random testing will be provided by the independent lab as necessary for compliance with the Specifications. The Contractor shall coordinate construction with the testing lab and the Town of Addison, and shall provide assistance to the testing labs by providing excavation, access, trench safety, materials for testing and any other Work required to insure all testing requirements are met. Work performed to accommodate testing will be a subsidiary item and no extra payment will be authorized. All costs for the field quality control testing shall be paid for by the Town of Addison, except for any and all re-testing, which shall be paid by the Contractor and such cost shall be deducted from monthly pay requests. As a guide, the Contractor shall be responsible for providing any test required by the Specifications.

All samples and tests shall be performed in accordance with the Standard Specifications for Public Works Construction, North Central Texas Council of Governments (5th Addition) as amended or supplemented.

36. **INSPECTION:** The Town of Addison and the Engineer reserve the right to inspect, test, measure or verify the construction Work for this Project as they deem necessary to ascertain that the Work is being accomplished in accordance with the standards and requirements set forth in the Contract Documents. Notwithstanding such reviews, the Contractor will be held responsible for the finished Work and any acceptance of the Work by the Town or governmental agencies will not relieve the Contractor from responsibility for the Work. The Town reserves the right to place full-time construction inspectors at the site of the Work. Costs for inspection services will be paid by the Town of Addison. The Contractor shall provide assistance to the Town of Addison and the Engineer by providing excavation, trench safety, or other Work necessary to facilitate inspection activities, and shall give sufficient notice well in advance of pending construction activities for scheduling of inspection services.

If the Specifications, the Town's instructions, laws, ordinances, or any public authority require any Work to be specially tested, the Contractor shall give the Town timely notice of its readiness for testing, and if the testing is by an authority other than the Town, of the date fixed for such testing. Tests by the Town shall be made promptly, and where practicable at the source of supply.

37. **ACCESS ROUTES, STAGING AREAS AND STORAGE AREAS:** All haul roads and access routes and the location of job site trailers, staging areas, and storage areas shall be subject to the approval of the Town and the Engineer. The Contractor shall be responsible for obtaining a staging area for storage of equipment and materials and for employee parking. The Contractor is responsible for maintaining and repairing all roads and other

PROJECT: ADDISON RAWHIDE CREEK BASIN DRAINAGE AND ADA IMPROVEMENTS FROM BROOKWOOD DR TO WATERSIDE CT

facilities used during construction. Upon completion of the Project all existing roads and other disturbed areas shall be left in a condition equal to that at the time the Contractor commences Work on this Project.

38. **PROPERTY ACCESS:** Access to adjacent commercial property shall be maintained at all times unless otherwise directed by the Engineer and/or Town of Addison. Contractor shall also maintain sufficient access throughout the Project limits to the existing buildings and businesses during construction operations.
39. **PLANT, PROCEDURES, METHODS AND EQUIPMENT:** The Contractor shall determine the methods to be employed, the procedures to be followed, and equipment to be used on the Work under this contract, subject to the requirements of these Specifications and approval of the Engineer and Town of Addison. Only adequate and safe procedures, methods and equipment shall be used.

The Contractor shall so arrange his Work and provide such plant and equipment as is necessary in order to meet the progress requirements of the approved time schedule and to complete the Work within the period of time as specified in the Contract. Only such materials and equipment as are necessary for the construction of the Work under this contract shall be placed, stored or allowed to occupy any space at the site of the Work.

It is expressly agreed that the acceptance or approval of any order of procedure, methods or equipment submitted or employed by the Contractor shall not in any manner relieve the Contractor of responsibility for the safety, maintenance and repairs of any Work, or for the construction maintenance and safety of the Work hereunder, or from any liability whatsoever on account of any procedure or method employed by the Contractor.

Where the Work under this contract requires permits from the Town of Addison, the State of Texas, or other public authorities, duplicate copies of such permits shall be furnished to the Engineer by the Contractor before the Work covered thereby is started. **NO WORK WILL BE ALLOWED TO PROCEED BEFORE REQUIRED PERMITS ARE OBTAINED AND DISTRIBUTED.**

40. **PARKING OF CONSTRUCTION EQUIPMENT:** During all other periods of time when the Contractor's or their sub-contractors equipment is not being actively used on the construction Work, the Contractor shall park the equipment at locations which are approved by the Town of Addison. The Contractor shall provide adequate barricades, markers and lights to protect the Town of Addison, the Engineer, the public and other Work. All barricades, lights, and markers must meet the requirements of the Town of Addison, State and Federal regulations.
41. **ZONING REQUIREMENTS:** During the construction of this Project, the Contractor shall comply with the present zoning requirements of the Town of Addison in the use of vacant property for storage purposes.
42. **IN PUBLIC ROADS AND PRIVATE DRIVES:** No public road shall be entirely closed overnight, unless approved by the Town of Addison. It shall be the responsibility of the Contractor to build and maintain all weather bypasses and detours, if necessary, and to

PROJECT: ADDISON RAWHIDE CREEK BASIN DRAINAGE AND ADA IMPROVEMENTS FROM BROOKWOOD DR TO WATERSIDE CT

properly light, barricade and mark all bypasses and detours that might be required on and across the roads involved in the Work included in this Contract.

The Contractor shall make every effort to complete construction and allow immediate access to adjacent property at driveway entrances located along the roadways. Towns or tenants of improvements where access and/or entrance drives are located shall be notified at least twenty-four (24) hours prior to the time the construction will be started at their driveways or entrances and informed as to the length of time driveways will be closed. Contractor shall at all times maintain at least one point of access into all properties, unless obtaining written permission from property owner to do otherwise with such written permission being provided to the Town's inspector.

The Contractor shall be responsible for all road and entrance reconstruction and repairs and maintenance of same for a period of two years from the date of Town of Addison's acceptance of the Work. In the event the repairs and maintenance are not made immediately to the satisfaction of the Town, and it becomes necessary for the Town to make such repairs, the Contractor shall reimburse the Town for the cost of such repairs.

The Contractor shall, at all times, keep a sufficient width of the roadway clear of dirt and other material to allow the free flow of traffic. The Contractor shall assume any and all responsibility for damage, personal or otherwise, that may be caused by the construction along roads and private drives.

43. **HAULING ON TOWN OF ADDISON STREETS:** The Contractor shall receive approval of its haul routes and type of equipment to be used prior to beginning construction. The Contractor shall be responsible for maintaining the cleanliness of existing paved roadways and shall provide equipment and manpower for that purpose.
44. **EXISTING POWER POLES & GUY WIRES:** The Contractor shall have the responsibility of coordinating with the proper authorities for the bracing, replacing or relocating of all utility poles and guy wires which interfere with the Work on this Project prior to beginning its construction operations. The Contractor will also be responsible for all damage to poles, guy wires, etc. that are damaged or destroyed by Contractor's operations.
45. **SAFETY RESTRICTIONS - WORK NEAR HIGH VOLTAGE LINES:** The contractor is responsible for the site safety of the project. Contractor shall follow governing regulatory requirements when working near high voltage lines, including but not limited to, OSHA 1926 and Town of Addison requirements.
46. **PROTECTION OF EXISTING UTILITIES AND STRUCTURES:** The location and dimensions shown on the Plans relative to existing utilities and subsurface structures are based on the best records and/or field information available and are not guaranteed by the Town of Addison or the Engineer to be accurate as to location and depth. It shall be the Contractor's responsibility to verify locations of adjacent and conflicting utilities sufficiently in advance of its activities in order that he may negotiate such restrictive locations with the Town of Addison of the conflicting utility and/or make local adjustments

PROJECT: ADDISON RAWHIDE CREEK BASIN DRAINAGE AND ADA IMPROVEMENTS FROM BROOKWOOD DR TO WATERSIDE CT

to provide adequate clearances. The Contractor shall take all necessary precautions in order to protect all utilities and services encountered, whether or not they are indicated on the Plans. All damage to utilities resulting from Contractor's operations shall be restored at its expense. The Town of Addison and the Engineer assume no responsibility for failure to show any or all of these utilities or structures on the Plans, or to show them in their exact locations. It is mutually agreed that such failure shall not be considered sufficient basis for claims for additional compensation for Extra Work or for increasing the pay quantities in any manner whatsoever, unless the obstruction encountered is such as to necessitate changes in the lines or grades, or requires the building of special Work, provisions for which are not made in the Plans, in which case, provisions in these Specifications for Extra Work shall apply.

47. **PUBLIC UTILITIES AND OTHER PROPERTY TO BE CHANGED:** In case it is necessary to change or move the property of a public utility, such property shall not be moved or interfered with until authorized by the Town of Addison or the Engineer. The right is reserved for the Owner of public utilities to enter upon the limits of the Project for the purpose of making such changes or repairs of their property that may be made necessary by performance of the Contract. The Contractor shall be responsible for coordination with the Town of Addison and the Engineer, and all utility companies whose utility lines or streets may be affected by the proposed improvements. The Contractor shall observe the following:
- a. Prior to any excavation, the Contractor shall determine the locations of all existing water, gas, sewer, electric, telephone, telegraph, television, pipelines and other underground utilities and structures.
 - b. After commencing Work, the Contractor shall use every precaution to avoid interference with existing underground and surface utilities and structures and protect them from damage.
 - c. Where the locations of existing underground and surface utilities and structures are indicated, these locations are generally approximate, and all items which may be encountered during the Work are not necessarily indicated. The Contractor shall determine the exact locations of all items indicated, and the existence and locations of all items not indicated.
 - d. The Contractor shall repair or pay for all damage caused by its operations to all existing utility lines, public property, and private property, whether it is below ground or above ground, and he shall defend and settle in total the cost of all lawsuits which may arise as a result of its operations.
 - e. To avoid unnecessary interferences or delays, the Contractor shall coordinate all utility removals, replacements and construction with the appropriate utility company, and then request written authorization from the Town of Addison or the Engineer. The Town of Addison and the Engineer will not be liable for damages due to delay as a result of the above.

PROJECT: ADDISON RAWHIDE CREEK BASIN DRAINAGE AND ADA IMPROVEMENTS FROM BROOKWOOD DR TO WATERSIDE CT

48. **MAINTENANCE AND REPAIRS:** The Contractor shall maintain and keep in good repair all Work contemplated under these Plans, Specifications, and Plans which shall include the maintenance and repair of all existing streets, storm sewer crossings, utility crossings, temporary crossings for access to adjacent property, barricades, lights, and danger signals, and all Work which is necessary for the well-being of the general public. In the event the Contractor fails in its obligations to properly maintain the Work, the Town of Addison shall make such repairs as are necessary and the cost of such repairs shall be deducted from payment due the Contractor.
49. **PROTECTION OF WORK:** During performance and up to date of final acceptance, the Contractor shall be under the absolute obligation to protect the finished Work against damage, loss or injury. In the event of damage, loss or injury, the Contractor shall promptly replace or repair such Work, whichever the Town of Addison shall determine to be preferable. The obligation to deliver finished Work in strict accordance with the contract prior to final acceptance shall be absolute and shall not be affected by the Town of Addison's approval of or failure to prohibit means and methods of construction used by the Contractor. All risk of loss or damage to the Work shall be borne solely by the Contractor until final acceptance of all Work by the Town of Addison, as evidenced by the Town of Addison's issuance of a certificate of acceptance.
50. **PUBLIC CONVENIENCE AND SAFETY:** In accordance with generally accepted construction practices, the Contractor shall be solely and completely responsible for conditions of the Project site, including safety of all persons and property during performance of the Work. This requirement shall apply continuously and not be limited to normal Work hours.

Materials stored about the Work site shall be so placed, and the Work shall at all times be so conducted, as to cause no greater obstruction to the traveling public than is considered necessary by the Town of Addison. The materials excavated shall be placed so as not to endanger the Work or prevent free access to all fire hydrants, water valves, gas valves, manholes (telephone, telegraph or electrical conduits, and sanitary sewers) and fire alarm or police call boxes in the vicinity.

The Town of Addison reserves the right to remedy any neglect on the part of the Contractor as regards to the public convenience and safety which may come to the Town of Addison's attention, after 24 hours notice in writing to the Contractor, save in cases of emergency, when the Town of Addison shall have the right to remedy any neglect without notice; and, in either case, the cost of such Work done by the Town of Addison shall be deducted from the monies due or to become due the Contractor. The Contractor shall notify the Town of Addison and the Engineer when any street is to be closed or obstructed. The Contractor shall provide for emergency vehicle access at all times.

Where the Work passes over or through private property, the Town of Addison shall provide such right-of-way. The Contractor shall notify the proper representatives of any public utility, corporation, company or individual, not less than 48 hours in advance of Work which might damage or interfere with the operation of their property along or adjacent to the Work. The Contractor shall be responsible for all damage or injury to

PROJECT: ADDISON RAWHIDE CREEK BASIN DRAINAGE AND ADA IMPROVEMENTS FROM BROOKWOOD DR TO WATERSIDE CT

property of any character (except such as may be required by the provisions of the Contract Documents, or caused by agents or employees or the Town of Addison) by reason of any negligent act or omission on the part of the Contractor, its employees, agents or Subcontractors, or at any time due to defective Work or materials, or due to its failure to reasonably or properly prosecute the Work, and said responsibility shall not be released by the fact that the Work shall have been completed and accepted.

When and where any such damage or injury is done to public or private property on the part of the Contractor, he shall restore or have restored at its own cost and expense such property to a condition similar or equal to that existing before such damage was done, by repairing, rebuilding or otherwise restoring as he may be directed, or he shall make good such damage or injury in a manner acceptable to the property Town of Addison and the Engineer. In case of failure on the part of the Contractor to restore such property or make good such damage or injury, the Town of Addison may, upon 48 hour written notice under ordinary circumstances, and without notice when a nuisance or hazardous condition results, proceed to repair, rebuild or otherwise restore such property as may be determined necessary, and the cost thereof shall be deducted from any monies due or to become due to the Contractor under this contract; or where sufficient contract funds are unavailable for this purpose, the Contractor or its surety shall reimburse the Town of Addison for all such costs.

- 51. PROTECTION OF PERSONS AND PROPERTY:** The Contractor shall have the responsibility to provide and maintain all warning devices and take all precautionary measures required by law or otherwise necessary to protect the Work and persons and property while said persons or property are approaching, leaving or within the Work site or any area adjacent to said Work site. No separate compensation shall be paid to the Contractor for the installation or maintenance of any protective measures, warning devices, barricades, lights, signs, or any other precautionary measures required by law or otherwise necessary for the protection of persons or property.

The Contractor shall assume all responsibilities to the general public in connection with the general public's immediate approach to and travel through the Work site and the area adjacent to said Work site.

Where the Work is in or adjacent to any street, alley, sidewalk, public right-of-way or public place, the Contractor shall at its own cost and expense provide such flagmen and watchmen and furnish, erect and maintain such warning devices, barricades, lights, signs, and other precautionary measures for the protection of persons or property as may be prudent or necessary, or as required by law. The Contractor's responsibility for providing and maintaining flagmen, watchmen, warning devices, barricades, signs and lights and other precautionary measures shall not cease until the Project shall have been completed and accepted by the Town of Addison, and shall cease when the Town of Addison notifies the Contractor in writing of final Project acceptance.

If the Town of Addison discovers that the Contractor has failed to comply with applicable federal or state laws (by failing to furnish the necessary flagmen, warning devices, barricades, lights, signs or other precautionary measures for the protection of persons or

PROJECT: ADDISON RAWHIDE CREEK BASIN DRAINAGE AND ADA IMPROVEMENTS FROM BROOKWOOD DR TO WATERSIDE CT

property), the Town of Addison may order the Contractor to take such additional precautionary measures as required by law to protect persons and property. In addition, the Contractor shall be held responsible for all damages to the Work and other public or private property due to the failure of warning devices, barricades, signs, lights or other precautionary measures in protecting said property; and whenever evidence is found of such damage, the Town of Addison may order the damaged portion immediately removed and replaced by and at the cost and expense of the Contractor.

52. TRAFFIC CONTROL: It shall be the responsibility of the Contractor to provide traffic control during the construction as required by the State of Texas, the Town of Addison, and in accordance with the following additional requirements:

- a. The Contractor shall be required to furnish barricades, flares, flagmen, etc., for the protection of the public, employees and the Work.
- b. The Contractor shall prosecute its Work in such a manner as to create a minimum of interruption to traffic along adjacent roadways.
- c. The unit price bid under the appropriate bid item of the proposal shall cover all cost for providing signage, markings, lighting, barricades, flagmen and other devices and personnel required for traffic control during construction of the Project.
- d. The Contractor shall not remove any regulatory sign, instructional sign, warning sign, street name sign or any other sign or signal which currently exists.
- e. **The Contractor shall provide a comprehensive Traffic Control Plan to the Town of Addison for review, comment, and approval.** In the event the planned sequence of work is different in any way from that sequence of work provided for in the plans or where additional details are required to be reviewed and approved by Addison prior to any further work is performed. The Traffic Control Plan shall be designed in accordance with established standards and regulations and signed and sealed by a professional engineer, registered in the State of Texas. The plan should reflect the Contractor's proposed construction phasing and methodology and include the design layout for all proposed detour and traffic situations. This effort is paid by lump sum in bid item A-31.

53. BARRICADES, WARNING SIGNS, DETOURS AND SEQUENCE OF CONSTRUCTION: Throughout the construction operations, streets and intersections will remain open to traffic by constructing the Work in stages. All streets, driveways, adjacent business and alleys shall remain open to traffic as far as is practicable.

- A. General Construction: The Contractor shall plan its Work sequence in a manner that will cause minimum interference with aircraft operations during construction operations. Before beginning Work on this Project, the Contractor shall submit, for approval by the Town of Addison, a plan of construction operations outlining in detail a sequence of Work to be followed; setting out the method of handling traffic on streets, roads and driveways along, across and adjacent to the Work. If at any time during the construction, the Contractor's proposed plan of operation for

PROJECT: ADDISON RAWHIDE CREEK BASIN DRAINAGE AND ADA IMPROVEMENTS FROM BROOKWOOD DR TO WATERSIDE CT

handling traffic does not provide for safe comfortable movement, the Contractor shall immediately change its operations to correct the unsatisfactory conditions.

Ditches across the traffic lanes will be kept covered with a portable traffic-bearing surface at all times unless Work in the ditch is in progress. Only one lane of traffic may be closed at a time when Work is in progress in a ditch.

- B. Safety: The Contractor shall provide, construct and maintain barricades and signs at locations set out in the Plans and in the Special Provisions in accordance with the Texas Manual on “Uniform Traffic Control Devices for Streets and Highways”. In addition, he shall provide and maintain such other barricades and signs as deemed necessary by the Town or the Engineer, and provide and maintain, between sunset and sunrise, a sufficient number of lights at barricades and points of danger for the protection of vehicular and pedestrian traffic.

Barricades shall be placed in such a manner as not to interfere with the sight distance of drivers entering the street from side streets.

The Contractor shall keep traveled surfaces used in its hauling operation clear and free of dirt or other material.

The Contractor shall provide and maintain qualified flagmen at such points and for such periods of time as may be required to provide for the safety and convenience of public travel and Contractor’s personnel.

54. EXCAVATION SAFETY SYSTEMS:

The Work performed under this section of the Specifications consists of providing trench safety systems consisting of shoring, sheeting, trench shield, and/or laid back slopes to meet the trench safety requirements of the Occupational Safety and Health Administration (O.S.H.A.), as required for this Project and specified herein.

- A. General: Trench safety systems shall be provided by the Contractor as provided in Subpart P - Excavation, Trenching and Shoring, Part 1926 of the Code of Federal Regulations which describes safety and health regulations as administered by the U.S. Department of Labor Occupational Safety and Health Administration (O.S.H.A.). The standards specified by the O.S.H.A. Regulations shall be the minimum allowed on this Project. It shall be the responsibility of the Contractor to design and install adequate trench safety systems for all trenches excavated on this Project.

The Contractor shall furnish to the Town for review, prior to beginning construction activity, a Trench Safety Plan for the entire Project. The trench safety plan must be prepared and sealed by a Professional Engineer registered in the State of Texas. In addition, all trench safety systems utilized in this Project must be designed by a Professional Engineer registered in the State of Texas. The Contractor shall be totally responsible for the safety of all persons involved in the construction of this Project.

PROJECT: ADDISON RAWHIDE CREEK BASIN DRAINAGE AND ADA IMPROVEMENTS FROM BROOKWOOD DR TO WATERSIDE CT

- B. Core Borings: Any core borings and soil data furnished by the Town are for the convenience of the Contractor. The Contractor shall be responsible for any additional soil or geotechnical information required. The Contractor shall be responsible for properly designed trench safety systems to be utilized for any type of subsurface condition found on this Project. The furnishing of soil information by the Town of Addison in no way relieves the Contractor of this obligation. If no core borings or soil data are furnished by the Town, it shall be the Contractor's responsibility to obtain whatever geotechnical information required for preparation of trench safety systems.
- C. Inspections: In addition to the inspections of the trench and trench safety systems required of the Contractor by the O.S.H.A. Regulations, the Town may further inspect the Work. The Town shall have the right to reject any trench safety systems which he finds to be inadequate, and the Contractor shall immediately improve the system to comply with this specification.
- D. Measurement and Payment: Measurement and payment of Trench Safety Systems shall be based on the actual linear footage of the pipe installed on the Project. The payment shall be full compensation for all planning, engineering, materials, equipment, fabrications, installation, recovery and all incidental Work required.
- 55. TRENCH EXCAVATION, BACKFILL AND COMPACTION:** Trench excavation, backfill and compaction of water and sewer utility trenches shall be in accordance with Town of Addison Standards and with details shown on the Construction Plans.
- A. Trench Excavation: If the stated maximum trench widths are exceeded, either through accident or otherwise, and if the Engineer determines that the design loadings of the pipe will be exceeded, the Contractor will be required to support the pipe with an improved trench bottom. The expense of such remedial measures shall be entirely the Contractor's own. All trenching operations shall be confined to the width of permanent rights-of-way, permanent easements and any temporary construction easements. All excavation shall be in strict compliance with the Trench Safety Systems Special Condition of this document.
- B. Trench Backfill: Trenches shall be backfilled above the top of the embedment material with approved backfill material per Town of Addison Standards for the appropriate pipe size, pipe material, depth, and soil condition.
- C. Compaction: All trenches under proposed or existing pavement shall be compacted to within a range of 95% to 100% Standard Proctor Density. Trenches which lie outside limits of pavement shall be compacted to a minimum of 90% Standard Proctor Density (ASTM D-698).
- 56. TRENCH WALLS:** The Contractor shall use shoring or a drag box in those areas where it is required to protect existing improvements. This shall be subsidiary to the linear foot cost of the pipe and not a separate pay item.

PROJECT: ADDISON RAWHIDE CREEK BASIN DRAINAGE AND ADA IMPROVEMENTS FROM BROOKWOOD DR TO WATERSIDE CT

57. **SUSPENSION OF WORK RELATED TO DANGER:** In addition to the other remedies for suspension of the Work as provided for in the General Provisions and Special Provisions, the Town of Addison has the authority to suspend all work immediately if, in the Town of Addison's opinion, there is imminent danger to workers or the general public. If there is no imminent danger to workmen or the general public, but trench conditions are not in compliance with Federal Regulations 29 C.F.R. 1926.650-1926.652, the Town of Addison shall warn the Contractor who shall then immediately order all workmen in and adjacent to the trench away from the area. The Contractor must then bring the trench into compliance with the regulations. If the Contractor does not make the required corrections, all work on the Contract shall cease and the Town of Addison will issue a letter of Temporary Suspension of Work. The only work authorized after issuance of this letter is work approved by the regulations. Other work shall not be permitted until the Town of Addison issues a letter of Release of Temporary Suspension of Work. The Contractor shall not be entitled to additional compensation, an extension of time or payment of damages as a result of a temporary suspension of work under this provision.
58. **PROPERTY LINES AND MONUMENTS:** The Contractor shall protect all property corner markers, and when any such markers or monuments are in danger of being disturbed, they shall be properly referenced and if disturbed shall be reset at expense of the Contractor.
59. **CONSTRUCTION STAKING:** Construction staking will not be provided by the Town of Addison or Engineer. This item will be performed by the Contractor and shall be subsidiary to other bid items. The Contractor will also be responsible for maintaining stakes. If re-staking is required for any reason, it will be the Contractor's responsibility, including associated costs.

All construction staking shall be done under the supervision of a Registered Professional Land Surveyor registered in the State of Texas. The Contractor shall submit copies of cut sheets and field books for the construction of all paving, water, wastewater, and stormwater improvements to the Town of Addison for review prior to construction of the improvements. The information on the cut sheets and field books shall include but not be limited to the following:

- a. Heading to include date, contract number, Project name, surveying firm, Contractor, and construction plan sheet number.
- b. Location, description of street/line and street/line name, number, letter, etc. designation.
- c. Benchmark Data: Location, description, and elevation.
- d. Slope or percent of grade of each curb line or utility line.
- e. Stations at 50 foot intervals and including all PC, PT, PI, PVC, PVI, PVT, PRC, grade changes, etc.

PROJECT: ADDISON RAWHIDE CREEK BASIN DRAINAGE AND ADA IMPROVEMENTS FROM BROOKWOOD DR TO WATERSIDE CT

- f. Offset description including distance to center line or back of curb and direction of offset; left, right, east, west, etc.
 - g. Cut to subgrade, pavement, top of curb, or flowline of the street or utility being staked.
 - h. Clarifying remarks such as top of curb, gutter, pavement, subgrade, manhole, cleanout, valve, tee, cross, fire hydrant, wastewater lateral, water service, etc.
 - i. Cut sheets shall be signed by a Texas Registered Professional Land Surveyor.
- 60. DURING CONSTRUCTION:** During construction of the Work, the Contractor shall, at all times, keep the site of the Work and adjacent premises as free from material, debris and rubbish as is practicable and shall remove same from any portion of the site if, in the opinion of the Town of Addison or the Engineer, such material, debris or rubbish constitutes a nuisance or is objectionable. In case of failure on the part of the Contractor to maintain a clean site, the Town of Addison may, upon 24 hour written notice, clean the site, and the cost thereof shall be deducted from any monies due or to become due to the Contractor under its contract; or where sufficient contract funds are unavailable for this purpose, the Contractor or its surety shall reimburse the Town of Addison for all such costs.
- 61. CONSTRUCTION TRAFFIC OVER PIPE LINES:** The design of the new pipes and the design of the existing pipe have been taken into account and provided for highway live loads. It is apparent, however, that certain construction vehicles could exceed this highway load condition under shallow bury conditions. It will be the responsibility of the Contractor to protect both the new line and the existing lines from these possibly excessive loads. The Contractor shall not at any time cross the existing or new pipe with a truck delivering new pipe to the site. Any damage to the existing or new pipe will be repaired or replaced by the Contractor to the satisfaction of the Town of Addison.
- In locations where it is not permissible to cross the existing or proposed pipes without additional protection, the Contractor may elect to provide additional protection of the pipes, such as steel plates, so that more frequent crossings of the pipes are allowed. It still is, however, the responsibility of the Contractor to repair any damage to the existing or proposed lines if the damage results from any phase of its construction operation.
- 62. CONTRACTOR'S CONTINUING OBLIGATION:** Contractor's obligation to perform and complete the Work in accordance with the Contract Documents shall be absolute. Neither recommendation of any progress or final payment by the Town of Addison, nor the issuance of a certificate of Substantial Completion, nor any payment by Town of Addison to Contractor under the Contract Documents, nor any use or occupancy of the Work or any part thereof by Town of Addison, nor any act of acceptance by Town of Addison nor any failure to do so, nor any review and approval of a Shop Drawing or sample submission, nor the issuance of a notice of acceptability by the Town of Addison pursuant to final payment nor any correction of defective Work by Town of Addison will constitute an acceptance of Work not in accordance with the Contract Documents or a release of Contractor's obligation to perform the Work in accordance with the Contract Documents.

PROJECT: ADDISON RAWHIDE CREEK BASIN DRAINAGE AND ADA IMPROVEMENTS FROM BROOKWOOD DR TO WATERSIDE CT

63. **IRRIGATION AND SPRINKLER REPAIR:** The Contractor shall maintain all existing irrigation systems within the limits of the Project during the duration of the contract, if necessary. The Contractor shall employ a licensed irrigator who is responsible for the repair or replacement of any damage to irrigation lines, valves, controllers, sprinklers, wiring and appurtenances which are damaged during construction. **This repair is subsidiary to the various other items bid. The Contractor will be responsible for any vegetation that dies as a result of damage to the irrigation system and replace it with equal vegetation at its own cost.**
64. **REMOVAL OF DEFECTIVE AND UNAUTHORIZED WORK:** All Work which has been rejected or condemned shall be repaired; or if it cannot be repaired satisfactorily, it shall be removed and replaced at the Contractor's expense. Defective materials shall be immediately removed from the Work site. Work done without line and grade having been provided; Work done beyond the line or not in conformity with the grades shown on the Plans or as provided, Work done without proper inspection; or any Extra or unclassified Work done without written authority and prior agreement in writing as to prices, shall be at the Contractor's risk and will be considered unauthorized, and at the option of the Town of Addison may not be measured and paid for and may be ordered removed at the Contractor's expense. Upon failure of the Contractor to repair satisfactorily or to remove and replace, if so directed, rejected, unauthorized or condemned Work or materials immediately after receiving notice from the Town of Addison, the Town will, after giving written notice to the Contractor, have the authority to cause defective Work to be remedied or removed and replaced, or to cause unauthorized Work to be removed and to deduct the cost thereof from any monies due or to become due the Contractor.
65. **DISPOSITION AND DISPOSAL OF MATERIALS:** All materials to be removed from the site including refuse and other debris shall become the property of the Contractor and shall be disposed of outside the limits of the Project. Contractor shall also comply with all applicable laws governing the spillage of debris while transporting to a disposal site.
66. **CLEAN-UP FOR FINAL ACCEPTANCE:** The Contractor shall make a final cleanup of all parts of the Work before acceptance by the Town of Addison. This cleanup shall include removal of all objectionable rock and other construction materials, and in general preparing the site of the Work in an orderly manner and appearance.
67. **TV INSPECTION OF SANITARY SEWER/STORM SEWER:** Part of the final inspection of the wastewater systems on this Project shall include a closed circuit TV survey of the completed pipe installation, exclusive of services, and all imperfections in the installed facility revealed by the TV survey shall be remedied by the Contractor prior to acceptance of the Project as complete. All TV survey Work, including furnishing of necessary personnel, equipment and material shall be performed by the Contractor.
68. **TESTING REQUIREMENTS:** Testing shall be conducted in accordance with Town of Addison Specifications except as modified in the Special Provisions, Technical Specifications, or as on the plans. The Town of Addison will provide random testing. The Contractor shall coordinate construction with the Town of Addison, and shall provide assistance to the testing labs by providing trench safety, excavation, or other work to insure

PROJECT: ADDISON RAWHIDE CREEK BASIN DRAINAGE AND ADA IMPROVEMENTS FROM BROOKWOOD DR TO WATERSIDE CT

all testing requirements are met. Work performed to accommodate testing will be a subsidiary item and no extra payment will be authorized. All retesting shall be at the expense of the Contractor. As a general guide, the Contractor shall be responsible for providing the following tests:

- a. Density and associated tests on embedment and backfill.
- b. Compressive strength tests on concrete.
- c. Gradation soil tests on backfill as may be required.
- d. Pressure test, bacteriological tests for disinfection of water lines,
- e. Mandrel test for gravity sewer pipeline
- f. Vacuum test for SSMH for water tightness.
- g. Providing test results from manufacturer and as specified in Town of Addison Specifications (NTCOG).

69. SILICONE JOINT SEALANT: Silicone joint sealant must be used in all instances where joint sealant applies to Portland Cement Concrete pavement and curbs. Payment for the use of silicone joint throughout this Project will in all cases be subsidiary to this contract at no extra cost.

70. CLAIMS FOR DAMAGES OR INJURY: General Provision Item 1.24.3 - SMALL CLAIMS FOR DAMAGE OR INJURY is amended to read as follows: “If any person files a claim against the Town of Addison or Contractor for personal injury or property damage resulting from, arising out of, or caused by, the operations of the Contractor, or any Work within the limits of the Project, the Contractor must either submit to the Town of Addison, a duly executed full release within thirty (30) days from the date of written claim, or immediately report the claim to its liability insurance carrier for their action in adjusting the claim. If the Contractor fails to comply with this provision within the stipulated time limit, it will be automatically deemed that the Contractor has appointed the Town as it’s irrevocably Attorney-In-Fact authorizing the Town to report the claim directly with the liability insurance carrier. This provision is in and of itself a Power-of-Attorney from the Contractor to the Town which authorizes the Town to take said action on behalf of the Contractor without the necessity of the execution of any other document. If the Contractor fails to comply with the provisions of this item the Town, at its own discretion, may terminate this contract or take any other actions it deems appropriate. Any payment or portion thereof due the Contractor, whether it is a final payment, progress payment, payment out of retainage or refund payment may be withheld by the Town as is authorized by Item 109.4. Bankruptcy, insolvency or denial of liability by the insurance carrier shall not exonerate the Contractor from liability.

As a result of the additional Work created to Town of Addison due to un-responded claims for damages by Contractor to third parties, Contractor shall incur penalties for failure to abide by this Special Provision.

PROJECT: ADDISON RAWHIDE CREEK BASIN DRAINAGE AND ADA IMPROVEMENTS FROM BROOKWOOD DR TO WATERSIDE CT

Contractor shall respond to the claimant in writing regarding the status of the claim, including whether Contractor disputes the claim, wishes to settle, or will notify its liability insurance carrier regarding the claim. Contractor will be assessed a penalty by the Town of \$75.00 per claim, for its failure to respond to the claimant as described above within thirty days of its written notice of claim by the Town.

To ensure Contractor compliance, the Town of Addison shall be notified, by copied correspondence of responses or settlement by Contractor.”

71. **WAIVER OF CLAIMS:** The making and acceptance of final payment will constitute:
- A. A waiver of all claims by Town of Addison against Contractor, except claims arising from unsettled Liens, from defective Work appearing after final inspection or failure to comply with the Contract Documents or the terms of any special guarantees specified therein; however, it will not constitute a waiver by Town of Addison of any rights in respect of Contractor’s continuing obligations under the Contract Documents.
 - B. A waiver of all claims by Contractor against Town of Addison other than those previously made in writing and still unsettled.
72. **MECHANICS AND MATERIALMEN’S LIEN:** The Contractor shall be required to execute a release of mechanics and materialmen’s liens upon receipt of payment and shall ensure that the Project remains free and clear of all liens related to the Work. The Contractor shall have all liens removed by obtaining releases acceptable to the Town of Addison or shall bond around such liens by obtaining a discharge of all liens.
73. **CONTRACTOR’S AFFIDAVIT OF BILLS PAID:** The Contractor shall be required to execute the form provided in Section BP prior to the acceptance of the Project.
74. **PRODUCT RECORD DOCUMENTS:** The Contractor shall maintain record Plans and legibly annotate shop drawings to record changes made after review. A red felt-tip marking pen shall be used for all recording.

Maintenance of Documents: The Contractor shall maintain at the job site one record copy of the Contract Plans, Specifications, Shop Drawings, Change Orders, other modification to the Contract, field test records and other documents submitted by Contractor in compliance with specification requirements. These documents shall be maintained at the job site apart from documents used for construction. These documents are not to be used for construction purposes. The documents shall be maintained in clean, legible condition. The documents shall be made available at all times for inspection by the Town.

Recording: Each document shall be labeled Project Record Copy in 2-inch high printed letters. The record documents shall be kept current. No Work shall be covered until required information has been recorded.

PROJECT: ADDISON RAWHIDE CREEK BASIN DRAINAGE AND ADA IMPROVEMENTS FROM BROOKWOOD DR TO WATERSIDE CT

Contract Plans: The appropriate drawing shall be legibly marked to record, where applicable:

- a. Horizontal and vertical location of underground utilities and appurtenances referenced to permanent surface improvements.
- b. Field changes of dimension and detail made during construction process.
- c. Changes made by Change Order or Supplemental Agreement.
- d. Details not on original Contract Plans.
- e. Manufacturer, trade name, catalog number and supplier of each product and item of equipment actually installed.
- f. Changes made by Change Order or Supplemental Agreement.
- g. Other matters not originally specified.

Shop Drawing: The Contractor shall maintain the Shop Drawings as record drawings and legibly annotate shop drawings to record changes made after review.

Submittal: At the completion of the Project, the Contractor shall deliver record Plans to the Town. The transmittal letter shall be accompanied, in duplicate, with:

- a. Date, Project title and number.
- b. Contractor's name and address.
- c. Title and number of each record document.
- d. Certification that each document as submitted is complete and accurate.
- e. Signature of Contractor or its authorized representative.

- 75. OWNERSHIP OF WORK AND MATERIALS:** All Work performed by Contractor pursuant to the Contract shall be the property of the Town of Addison. The Town of Addison shall own all construction, and any data, documents, plans, specifications, working papers, computer programs, photographs, or other material produced by Contractor pursuant to the Contract, and Contractor hereby assigns and transfers to the Town of Addison any and all copyrights for such material. To the extent that such programs used are internal, proprietary programs used by Contractor in the performance of the Work, Contractor will provide the Town of Addison such access to the programs as is necessary for the Town of Addison to be able to use the products and documents generated by the program, but Contractor is not required to transfer the copyrights or other intellectual property rights to the program to the Town of Addison. As security for partial, progress, or other payments, title to work for which such payments are made shall pass to the Town of Addison at the time of the payment. To the extent that title has not previously been vested in the Town of Addison by reason of payments, full title shall pass to the Town of Addison at delivery of the Work at the location specified in the Contract.

Unincorporated Work to which the Town of Addison has received title by reason of progress, partial or other payments shall be segregated from other Contractor or Subcontractor materials and clearly identified as the Town of Addison property. The

PROJECT: ADDISON RAWHIDE CREEK BASIN DRAINAGE AND ADA IMPROVEMENTS FROM BROOKWOOD DR TO WATERSIDE CT

Contractor shall be responsible for all materials until they have been incorporated into the Work and the Work has been finally accepted by the Town of Addison. The title transferred as above shall in each case be good, and free and clear of any and all security interests, liens, or other encumbrances. The Contractor promises and agrees that it will not pledge, hypothecate, or otherwise encumber the items in any way that would result in any lien, security interest, charge, or claim upon or against said items. The transfer of title as provided above shall not imply acceptance by the Town of Addison, nor relieve Contractor from the responsibility to strictly comply with the Contract, and shall not relieve Contractor of responsibility for any loss of or damage to such items.

The Contractor shall insert provisions in its subcontracts sufficient to ensure compliance with the content of this Section.

76. **DRAWINGS AND OTHER DATA:** All documents developed by Contractor in the performance of the Contract shall become the sole property of the Town of Addison and may be used by the Town of Addison on any other project without additional compensation to Contractor. Use by the Town of Addison of these documents on other projects does not confer any liability on Contractor.

The Town of Addison shall be considered the “person for whom the work was prepared” for the purpose of authorship in any copyrightable work under 17 U.S.C. § 201(b). With respect thereto, Contractor agrees not to assert or authorize others to assert any rights or establish any claim under the design related patent and copyright laws. All design drawings, as-built drawings and specifications, in any form, shall contain a copyright mark of the Town of Addison.

77. **TOWN OF ADDISON APPROVAL:** This Project is subject to final approval and acceptance by the Town of Addison. Final approval acceptance will not be given until the punch list items are completed to the Town’s satisfaction and as-built Plans are given to the Town of Addison.
78. **USE OF EXPLOSIVES:** The use of explosives by the Contractor to complete the Work shall be prohibited.
79. **POWER FOR CONSTRUCTION:** The Contractor shall contract with the local power provider and make the necessary arrangements for securing power required for the construction, including power required for temporary offices. There will be no separated pay item for connection into the existing power system or for the power required for construction purposes.
80. **LIQUIDATED DAMAGES:** If the Contractor fails to complete the Work within the time specified in the contract, the Contractor shall pay liquidated damages to the Town of Addison in the amount of \$ 1,000 for each calendar day of delay until the Work is completed or accepted.
81. **CONTRACT DELAY:** The parties anticipate that delays may be caused by or arise from any number of events during the course of the Contract, including, but not limited to, Work performed, disruptions, permitting issues, actions of subcontractors, suppliers, or other

PROJECT: ADDISON RAWHIDE CREEK BASIN DRAINAGE AND ADA IMPROVEMENTS FROM BROOKWOOD DR TO WATERSIDE CT

contractors, actions by third parties, weather, weekends, holidays, or other such events, forces or factors sometimes experienced in construction work. Such delays or events and their potential impacts on performance by the Contractor are specifically contemplated and acknowledged by the parties in entering into this Contract, and shall not extend the Contract time for completion. Further, any and all costs or impacts whatsoever incurred by the Contractor in accelerating the Work to overcome or absorb such delays or events in an effort to complete the Contract prior to expiration of the Contract time to complete, regardless of whether the Contractor does so or not, shall be the sole responsibility of the Contractor in every instance.

- 82. SUBCONTRACTORS:** No subcontract shall relieve Contractor of any of Contractor's obligations or liabilities under the Contract. Contractor shall be fully responsible and liable for the acts or omissions of all Subcontractors, including persons directly or indirectly employed by them, their guests and invitees. Contractor shall have sole responsibility for managing and coordinating the operations of its Subcontractors, including the settlement of disputes with or between them. Nothing contained in the Contract shall be deemed to create a contractual relationship between any Subcontractor, and the Town of Addison.

Contractor shall provide to the Town of Addison one (1) copy of all executed subcontracts associated with the Contract, including any changes or modifications to the subcontracts, within three (3) days of their execution. No Subcontractor shall be permitted to perform work associated with the subcontract until the Subcontractor (or Contractor on the Subcontractor's behalf) is in compliance with the insurance requirements specified elsewhere in the Contract and has furnished satisfactory evidence of insurance to the Town of Addison.

- 83. PAYMENTS TO SUBCONTRACTORS:** Contractor shall comply with the provisions of applicable laws and regulations relating to Contractor's relations with Subcontractors. Payments by Contractor to Subcontractors associated with the Town of Addison Contracts are subject to the time periods established in the Texas "Prompt Payment Act", contained in Chapter 2251 of the Texas Government Code.

All persons employed in the performance of the Work under the Contract, or any subcontracts hereunder, shall be paid not less than the general rates of per diem, holiday, and overtime wages prevailing in the locality of the Work of a similar character as detailed in the Special Provisions. Failure to comply with this provision shall subject Contractor to the penalties prescribed in Chapter 2258 of the Texas Government Code, as amended.

Contractor will include in each subcontract for property or services entered into by Contractor and a Subcontractor, including a supplier, for purposes of performing the Work under the Contract a payment clause that obligates Contractor to pay the Subcontractor for satisfactory performance under its subcontract within seven (7) days out of such amounts as are paid to Contractor by the Town of Addison under the Contract. A false certification to the Town of Addison under the provisions of the Payments clause may be a principal offense in violation of Section 37.10 of the Texas Penal Code.

PROJECT: ADDISON RAWHIDE CREEK BASIN DRAINAGE AND ADA IMPROVEMENTS FROM BROOKWOOD DR TO WATERSIDE CT

- 84. USE OF COMPLETED PORTIONS OF THE WORK:** Whenever, as determined by the Town of Addison, any portion of the Work performed by Contractor is in a condition suitable for use, and the best interests of the Town of Addison requires such use the Town of Addison may take possession of or use such portion of the Work. Such use by the Town of Addison shall in no case be construed as final acceptance and shall neither relieve Contractor of any of its responsibilities under the Contract, nor act as a waiver by the Town of Addison of any of the conditions thereof. Contractor shall not be liable for the cost of repairs, rework, or renewals, which may be required due to ordinary wear and tear resulting from such use. However, if such use increases the cost or delays the completion of remaining portions of the Work, Contractor shall notify the Town of Addison in writing as required by the Contract and shall be entitled to such additional compensation or extension of time, or both, as determined in accordance with the Contract.

If in the course of such use, the Work proves to not be in compliance with the Contract, the Town of Addison shall have the right to continue such use until such portion of the Work can, without injury to the Town of Addison, be taken out of service for correction of defects, errors, omissions, or replacement of unsatisfactory materials, as necessary for such portions of the Work to comply with the Contract. Contractor shall correct the Work as soon as practical, but not later than one (1) month after notification by the Town of Addison.

Contractor shall not use any permanently incorporated materials unless such use is approved in writing by the Town of Addison. Where Contractor's request is granted for the use of certain materials, Contractor shall properly use and maintain and, upon completion of its use and at its own expense, recondition such materials to the satisfaction of the Town of Addison.

- 85. COMPLETE AGREEMENT:** The Contract (including Attachments, the Special Provisions, other documents and manuals incorporated herein) is the full and complete agreement between the Town of Addison and Contractor with respect to the subject matter herein and supersedes any and all prior agreements between the parties hereto.
- 86. WAIVER:** The waiver by the Town of Addison of the breach of any provision of the Contract by Contractor shall in no way impair the right of the Town of Addison to enforce the provision for any subsequent breach thereof. All remedies provided hereunder are cumulative and are in addition to all other remedies available at law or in equity.
- 87. EXECUTION OF THE CONTRACT:** The Contract may be executed in multiple counterparts, each of which shall, for all purposes, be deemed an original but which together shall constitute one and the same instrument, and the signature pages from any counterpart may be appended to any other counterpart to assemble fully executed documents, and counterparts of the Contract may also be exchanged via electronic facsimile machines and any electronic facsimile of any party's signature shall be deemed to be an original signature for all purposes.

PROJECT: ADDISON RAWHIDE CREEK BASIN DRAINAGE AND ADA IMPROVEMENTS FROM BROOKWOOD DR TO WATERSIDE CT

- 88. DEFINITIONS:** The following definitions are added to the General Provisions and Special Provisions:

BIDDER: Any person, persons, partnership, company, firm, association, or corporation acting directly or through a duly authorized representative submitting a proposal for the work contemplated.

PROJECT: The Town of Addison’s overall objective and endeavor of which the Contract forms a part and ultimately creates, which encompasses all Contract Documents constructed to final completion and final acceptance.

TOWN ENGINEER (ENGINEER): Town Engineer or his/her authorized representative with the Town of Addison located at 16801 Westgrove Drive, Addison, Texas 75001.

CONSULTANT ENGINEER (DESIGN ENGINEER): The consultant engineer of record is Sherry L. Williams, PE (Texas Registered PE #87940 with Criado & Associates, Inc. located at 4100 Spring Valley Road, Dallas, TX 75244.

WORKING DAY: A working day is defined as a calendar day not including Saturdays, Sundays, or legal holidays authorized in the list prepared by the City of Dallas for contract purposes, in which weather or other conditions not under the control of the Contractor shall permit the performance of the principal units of work underway for a continuous period of not less than 7 hours between 7 A.M. and 6 PM. A principle unit of work shall be that unit which controls completion time of the contract. Nothing in this definition shall be construed as prohibiting the Contractor from working on Saturdays, if the Contractor so desires and permission of the Town of Addison has been granted. Work on Sundays shall not be permitted except in cases of extreme emergency and then only with the written permission of the Town of Addison. If Saturday or Sunday work is permitted, working time shall be charged on the same basis as weekdays. Where the working time is expressed as calendar days or a specific date, the concept of working days shall no longer be relevant to the contract.

- 89. MODIFICATIONS TO THE LANGUAGE OF THE GENERAL PROVISIONS:** The General Provisions are modified as follows:

- A. Add the following words to the General Provisions before the word “Certificates” found on the fifth line of Section 103.4.1:

“When permitted by law,”

- B. Delete the sentence “A model Certificate of Insurance is illustrated in Model Form A.6 in Appendix A.” beginning on the eleventh line of Section 103.4.1 of the General Provisions and replace with the following:

“Certificates of Insurance shall be provided on a state approved form.”

PROJECT: ADDISON RAWHIDE CREEK BASIN DRAINAGE AND ADA IMPROVEMENTS FROM BROOKWOOD DR TO WATERSIDE CT

- C. Delete the following sentence beginning on the second line of the fifth subparagraph of Section 104.2.1 of the General Provisions:

“The foregoing notwithstanding, the total original Contract amount shall not be increased more than 25 percent; the CONTRACTOR, by submission of a proposal and execution of the Contract, is deemed to consent to the OWNER’S right to reduce the total original Contract amount by more than 25 percent.”

- D. Add the following word before the word “decide” found on the second line of Section 105.7.1 of the General Provisions:

“initially”

- E. Add the following word after the word “work” found on the sixth line of Section 105.7.1 of the General Provisions:

“, subject to the agreement of the Owner”

- F. Delete the following sentence beginning on the sixth line of Section 105.7.1 of the General Provisions:

“Engineer shall determine the amount and quality of work performed and materials furnished, and Engineer’s decision and estimates shall be final.”

- G. Delete Section 105.9.3 of the General Provisions titled “Inspection Overtime” in its entirety.

- H. Delete Section 107.3 of the General Provisions titled “Indemnification” in its entirety and replace with the following:

“THE CONTRACTOR AGREES TO INDEMNIFY, SAVE, PROTECT, DEFEND, AND HOLD HARMLESS THE OWNER, ITS AFFILIATES AND THEIR OFFICERS, DIRECTORS, AGENTS, INVITEES, AND EMPLOYEES (“INDEMNIFIED PARTIES”) FROM AND AGAINST ANY AND ALL LIABILITY, COST, DAMAGE, EXPENSES, FINES AND ALL REASONABLE LEGAL FEES AND COURT COSTS, CLAIMS, LOSSES, CAUSES OF ACTION, SUITS, AND LIABILITY OF ANY KIND, INCLUDING ALL EXPENSES OF LITIGATION AGAINST THE INDEMNIFIED PARTIES, WHETHER OR NOT CAUSED IN PART BY ANY ACT OR OMISSION OF A PERSON OR ENTITY INDEMNIFIED HEREUNDER, OR WHETHER LIABILITY IS IMPOSED UPON SUCH PERSON OR ENTITY, FOR ANY LOSS, INJURY, DAMAGE OR DEATH ARISING FROM OR OUT OF THE CONTRACTOR’S ACTS

PROJECT: ADDISON RAWHIDE CREEK BASIN DRAINAGE AND ADA IMPROVEMENTS FROM BROOKWOOD DR TO WATERSIDE CT

OR OMISSIONS, INCLUDING, BUT NOT LIMITED TO CONTRACTOR'S NEGLIGENT OR GROSSLY NEGLIGENT PERFORMANCE OF THE WORK; NEGLIGENT OR GROSSLY NEGLIGENT USE OR MISUSE OF OWNER'S PROPERTY; NEGLIGENT OR INTENTIONAL ACTIONS, ERRORS OR OMISSIONS AND THOSE OF ITS EMPLOYEES, OFFICERS, DIRECTORS, AGENTS OR SUBCONTRACTORS; VIOLATION OF ANY FEDERAL, STATE OR MUNICIPAL LAWS, REGULATIONS AND/OR ORDINANCES; CONTRACTOR'S OR ITS SUBCONTRACTOR'S USE OF PROPERTY, EQUIPMENT, VEHICLES, OR MATERIALS; DEFECTIVE WORKMANSHIP; NEGLIGENT OR GROSSLY NEGLIGENT USE OR MISUSE OF UTILITIES; OR SUBCONTRACTORS', EMPLOYEES', AGENTS', OFFICERS', OR DIRECTORS' NEGLIGENCE OR INTENTIONAL TORTS. IT IS THE EXPRESS INTENT OF CONTRACTOR TO INDEMNIFY THE INDEMNIFIED PARTIES FROM THE CONSEQUENCES OF THEIR JOINT AND/OR CONCURRENT NEGLIGENCE AND/OR SOLE NEGLIGENCE. IN THE EVENT OF FAILURE BY THE CONTRACTOR TO FULLY PERFORM IN ACCORDANCE WITH THIS INDEMNIFICATION PARAGRAPH, EACH OF THE INDEMNIFIED PARTIES, AT ITS OPTION, AND WITHOUT RELIEVING CONTRACTOR OF ITS OBLIGATIONS HEREUNDER, MAY SO PERFORM, BUT ALL COSTS AND EXPENSES SO INCURRED BY ANY OF THE INDEMNIFIED PARTIES IN THAT EVENT SHALL BE REIMBURSED BY CONTRACTOR TO THE INDEMNIFIED PARTIES, OR ANY OF THEM, AND UNTIL REIMBURSED BY CONTRACTOR SHALL BEAR INTEREST, AT THE RATE OF INTEREST PROVIDED TO BE PAID ON JUDGMENT UNDER THE LAWS OF THE STATE OF TEXAS. THIS INDEMNIFICATION SHALL NOT BE LIMITED TO DAMAGES, COMPENSATION OR BENEFITS PAYABLE UNDER INSURANCE POLICIES, WORKERS' COMPENSATION ACTS, DISABILITY BENEFIT ACTS OR OTHER EMPLOYEE BENEFIT ACTS.

IN THE EVENT THIS CONTRACT RELATES TO A PROJECT OTHER THAN A SINGLE FAMILY HOUSE, TOWNHOUSE, DUPLEX, OR LAND DEVELOPMENT DIRECTLY RELATED THERETO OR A PUBLIC WORKS PROJECT OF A MUNICIPALITY THEN THE INDEMNITY PROVISIONS INCLUDED HEREIN SHALL BE LIMITED SUCH THAT SUBCONTRACTOR SHALL NOT BE REQUIRED TO INDEMNIFY, HOLD HARMLESS OR

PROJECT: ADDISON RAWHIDE CREEK BASIN DRAINAGE AND ADA IMPROVEMENTS FROM BROOKWOOD DR TO WATERSIDE CT

DEFEND CONTRACTOR OR ANY THIRD PARTIES AGAINST A CLAIM CAUSED BY THE NEGLIGENCE OR FAULT, THE BREACH OR VIOLATION OF A STATUTE, ORDINANCE, GOVERNMENTAL REGULATION, STANDARD, OR RULE, OR THE BREACH OF CONTRACT OF AN INDEMNIFIED PARTY, ITS AGENT OR EMPLOYEE, OR ANY THIRD PARTY UNDER THE CONTROL OR SUPERVISION OF THE INDEMNIFIED PARTY, OTHER THAN SUBCONTRACTOR OR ITS AGENT, EMPLOYEE, OR SUBCONTRACTOR OF ANY TIER EXCEPT THAT SUBCONTRACTOR SHALL INDEMNIFY, HOLD HARMLESS AND DEFEND THE INDEMNIFIED PARTY AGAINST ANY CLAIMS FOR THE BODILY INJURY OR DEATH OF AN EMPLOYEE OF SUBCONTRACTOR, ITS AGENTS, OR ITS SUBCONTRACTORS OF ANY TIER.

NOTWITHSTANDING ANYTHING HEREIN TO THE CONTRARY, THE INDEMNITY PROVISIONS INCLUDED HEREIN SHALL BE LIMITED SUCH THAT CONTRACTOR SHALL NOT BE REQUIRED TO INDEMNIFY, HOLD HARMLESS OR DEFEND OWNER OR ANY THIRD PARTIES AGAINST A CLAIM CAUSED BY THE NEGLIGENCE OR FAULT, THE BREACH OR VIOLATION OF A STATUTE, ORDINANCE, GOVERNMENTAL REGULATION, STANDARD, OR RULE, OR THE BREACH OF CONTRACT OF THE INDEMNIFIED PARTIES, ITS AGENT OR EMPLOYEE, OR ANY THIRD PARTY UNDER THE CONTROL OR SUPERVISION OF THE INDEMNIFIED PARTIES, OTHER THAN CONTRACTOR OR ITS AGENT, EMPLOYEE, OR SUBCONTRACTOR OF ANY TIER EXCEPT THAT CONTRACTOR SHALL INDEMNIFY, HOLD HARMLESS AND DEFEND THE INDEMNIFIED PARTIES AGAINST ANY CLAIMS FOR THE BODILY INJURY OR DEATH OF AN EMPLOYEE OF CONTRACTOR, ITS AGENTS, OR ITS SUBCONTRACTORS OF ANY TIER.”

- I. Add the following language after Section 103.3.1.4 of the General Provisions:

“103.3.1.5. Maintenance Bond. A good and sufficient bond in an amount not less than **100-percent** of the approximate total of the Contract, as evidenced by the proposed tabulation, or conditioned on the full and proper maintenance and repair of the Work to be done and performed for a period of one year from the date of final acceptance of the Work and the Contractor will do all necessary backfilling that may arise on account of sunken conditions in ditches, or otherwise, and do and perform the necessary Work and repair any defective condition growing out of or

PROJECT: ADDISON RAWHIDE CREEK BASIN DRAINAGE AND ADA IMPROVEMENTS FROM BROOKWOOD DR TO WATERSIDE CT

arising from the improper laying or construction of same, or on account of any breaking of same caused by the Contractor in construction of same, or on account of any defect arising in any of the Work laid or constructed by the Contractor or on account of improper excavation or backfilling, it being understood that the purpose of this Section is to cover all defective conditions arising by reason of defective materials, Work, or labor performed by the Contractor.”

J. Add the following language after Section 104.2.5. of the General Provisions:

“104.2.6. Change Orders. A Change Order is a written instrument and signed by the Owner, Contractor and Engineer stating their agreement upon all of the following:

- (1) the change in the Work;
- (2) the amount of the adjustment, if any, in the Contract Sum;
and
- (3) the extent of the adjustment, if any, in the Contract Time.

In the event the Contractor proposes a Change Order, the Contractor shall provide sufficient detail for such Change Order to allow analysis and review by the Engineer.

Agreement on any Change Order shall constitute final agreement on the Work which is the subject of the Change Order, including, but not limited to, all direct and indirect costs associated with such change and any and all adjustments to the Contract Sum and the Contract Time. In the event a Change Order increases the Contract Sum, the Contractor shall include the Work covered by such Change Orders in Applications for Payment as if such Work were originally part of the Contract Documents.

The Contractor, upon receipt of written notification by the Owner or the Engineer of a proposed item or change in Work, shall prepare as soon as possible a Change Order on the form provided by the Owner. If the Change Order is returned to the Contractor for additional information or if the scope of the proposed change in the Work is modified by additions, deletions or other revisions, the Contractor shall revise the Change Order accordingly and resubmit the revised Change Order to the Owner and Engineer.”

K. Delete the language in Section 105.2.1 of the General Provisions and replace it with the following language:

“105.2.1. WORKMANSHIP: If the OWNER notifies the CONTRACTOR in writing of defective work, the CONTRACTOR shall correct the deficiencies within five (5) calendar days of the

PROJECT: ADDISON RAWHIDE CREEK BASIN DRAINAGE AND ADA IMPROVEMENTS FROM BROOKWOOD DR TO WATERSIDE CT

Notice at no additional cost to the OWNER. If the defective work is not corrected within five (5) calendar days, or the CONTRACTOR is not making satisfactory progress (in the opinion of the OWNER) to correct the deficiencies, the OWNER may withhold future payments for All Work until the defective work has been corrected to the satisfaction of the OWNER.”

- L. Add the following language after Section 105.10 of the General Provisions:

“105.10.2. GUARANTEE AFTER COMPLETION: Unless otherwise specified in the technical section of these specifications, the CONTRACTOR shall, after test and acceptance, and for a period of one year from date of final written acceptance by the OWNER or within such longer or shorter period of time as may be prescribed by law or by the terms of any other applicable special warranty on designated equipment or portions of work as required by the Contract Documents, rebuild, repair, or replace any and all items which have proven defective due to unsatisfactory material and/or workmanship. Upon written notice from the OWNER, the CONTRACTOR shall immediately make any repairs that may be ordered, or such repairs will be made by the Owner at the expense of the CONTRACTOR or the CONTRACTOR’S Surety. In case of an emergency where delay would cause serious loss or damage, the Owner may undertake to have the defects repaired without previous notice. The expense of all repairs, including all emergency repairs, shall be borne by the CONTRACTOR or the CONTRACTOR’S Surety, at no cost to the Owner. This obligation shall survive termination of the Contract.

105.10.3. OFFSET PROGRESS PAYMENTS: OWNER may, at its option, offset any progress payment or final payment under the Contract Documents against any debt (including taxes) lawfully due to OWNER from Contractor, regardless of whether the amount due arises pursuant to the terms of the Contract Documents or otherwise and regardless of whether or not the debt due to OWNER has been reduced to judgment by a court.

105.10.4. FINAL ACCEPTANCE AND PAYMENT: This Project is subject to final inspection and final acceptance by the Owner. Whenever the Work provided for by the Contract shall have been completely performed on the part of the CONTRACTOR, including, but not limited to compliance with North Central Texas Council of Governments Standard Specifications for Public Works Construction, November 2017 Section 202.6.4.6., the CONTRACTOR shall notify the OWNER that the Work is ready for final inspection. The OWNER will then make such final inspection and if the work is satisfactory and in accordance with the

PROJECT: ADDISON RAWHIDE CREEK BASIN DRAINAGE AND ADA IMPROVEMENTS FROM BROOKWOOD DR TO WATERSIDE CT

specifications and contract documents, the OWNER shall issue a certificate of acceptance to the CONTRACTOR and submit a request to accept the Work performed by the CONTRACTOR and payment of a final estimate under the terms of which the OWNER will release 100% of the retainage, plus the unpaid portions of the final estimate as the OWNER deems advisable.

Whenever the improvements provided for by the Contract shall have been completely performed on the part of the Contractor, as evidenced in the certificate of acceptance, and all required submissions provided to the OWNER, a final estimate showing the value of the Work shall be prepared by the OWNER as soon as the necessary measurements and computations can be made. All prior estimates upon which payments have been made are subject to necessary corrections or revisions in the final payment. The amount of this final estimate, less any sums that have been previously paid, deducted or retained under the provisions of the contract, shall be paid the CONTRACTOR within 30 days after the final acceptance by the OWNER, provided the CONTRACTOR has furnished to the OWNER a consent of Surety and satisfactory evidence that all indebtedness connected with the Work and all sums of money due for any labor, materials, apparatus, fixtures, or machinery furnished for and used in the performance of the Work have been paid or otherwise satisfied, or that the person or persons to whom the same may respectively be due have consented to such final payment. This requirement is not intended and shall not be construed to recognize subcontractors for the purpose of privity of contract, and no third party benefit rights shall be obtained through these provisions for final payment. The acceptance by the CONTRACTOR of the final payment as aforesaid shall operate as and shall be a release to the OWNER from all claims or liabilities under the Contract, including all subcontractor claims, for anything done or furnished or relating to the Work under the Contract or for any act or neglect of said OWNER relating to or connected with the Contract.

All warranties and guarantees shall commence from the date of the certificate of acceptance. No interest shall be due the CONTRACTOR on any partial or final payment, or on the retainage.

105.10.5. RIGHT TO AUDIT CONTRACTOR'S RECORDS: By execution of the Contract, CONTRACTOR grants the OWNER the right to audit, at Owner's election, all of CONTRACTOR'S records and billings relating to the performance of the Work under the Contract. CONTRACTOR agrees to retain such records for a minimum of three (3) years following completion of the Work under this Contract. OWNER agrees that it will exercise the right to audit only at reasonable hours."

PROJECT: ADDISON RAWHIDE CREEK BASIN DRAINAGE AND ADA IMPROVEMENTS FROM BROOKWOOD DR TO WATERSIDE CT

- M. Add the following language after Section 107.6 of the General Provisions:

“107.6.1. COMPENSATION AND ACKNOWLEDGEMENT OF WORK: The CONTRACTOR shall receive and accept compensation, as herein provided, as full payment for furnishing all labor, tools, material, equipment and incidentals; for performing all Work contemplated and embraced under the Contract; for all loss or damage arising out of the nature of the Work, or from the action of the elements; for any unforeseen defects or obstruction which may arise or be encountered during the prosecution of the Work and before its final acceptance by the OWNER; for all risks of whatever description connected with the prosecution of the Work; for all expense incurred by or in consequence of suspension or discontinuance of such prosecution of the Work as herein specified; for any infringement of patents, trademarks or copyrights; and for completing the Work in an acceptable manner according to the Plans and Specifications.”

- N. Add the following language after Section 107.12 of the General Provisions:

“107.12.1. COOPERATION OF THE CONTRACTOR: The CONTRACTOR shall give to the work the consistent attention necessary to facilitate the progress thereof, and the CONTRACTOR shall cooperate with the OWNER, and with other CONTRACTORS in every way possible.

The OWNER and the OWNER’S representatives shall at all times have free access to the Work whenever it is in preparation or progress and the contractor shall provide safe, convenient and proper facilities for such access and inspection.”

- O. Delete Section 107.5 of the General Provisions and replace it with the following:

“107.5. VENUE AND CHOICE OF LAW

The Owner, the Contractor, and the Contractor’s sureties agree that this Contract shall be performed in Dallas, Dallas County, Texas, and if legal action is necessary in connection therewith, exclusive venue shall lie in Dallas County, Texas. The terms and provisions of the Contract Documents shall be construed in accordance with the laws and court decisions of the State of Texas.”

- P. Delete the following language (which is the first paragraph) from Section 109.5.1. of the General Provisions:

“Between the 25th day and the last day of each month, the Owner shall make an approximate estimate of the value of the work done during the month under the specifications. Whenever the said

PROJECT: ADDISON RAWHIDE CREEK BASIN DRAINAGE AND ADA IMPROVEMENTS FROM BROOKWOOD DR TO WATERSIDE CT

estimate or estimates of work done since the last previous estimate exceeds \$100 in amount, a percentage of such estimate sum shall be paid the Contractor on or before the 15th day of the month next following. The monthly estimate may include acceptable nonperishable materials delivered to the work; such payment shall be allowed on the same percentage basis of the net invoice value as provided hereinafter. The percent retained by the owner shall normally be up to 10 percent at completion, unless otherwise stated. At the midpoint, or at any subsequent time, if the owner determines that the progress of the Contract is satisfactory in all respects, it may at its discretion cease to retain additional funds until the completion of the project, or until progress ceases to be satisfactory. The owner shall make the sole determination in this matter.”

Q. Add the following language after Section 109.5.1. of the General Provisions:

“109.5.1.1. Applications for Payment. Applications for progress payment (“Application for Payment”) will be submitted no more often than monthly and shall be submitted on the dates set forth in the Agreement. Each Application for Payment shall be (1) sworn to and notarized, (2) supported by such data substantiating the Contractor’s right to payment as the Owner or Engineer may require, such as copies of requisitions from Subcontractors and material suppliers, and reflecting retainage if provided for in the Contract Documents, and (3) submitted by the Contractor for review to the Engineer in form and substance as mandated by the Owner. The Contractor’s Application for Payment shall be segregated and detailed in a manner satisfactory to the Owner.

In each Application for Payment, the Contractor shall certify that such Application for Payment represents a just estimate of portion of the Work that is complete as of the last day covered by the Application for Payment and shall also certify by sworn affidavit as follows:

‘There are no known mechanics’ or materialmen’s liens outstanding at the date of this Application, all due and payable bills with respect to the Work have been paid to date or shall be paid from the proceeds of this Application for Payment, there is no known basis for filing of any mechanics’ or materialmen’s liens on the Work, and waivers from all subcontractors and materialmen have been or, at the time of payment, will be obtained in such form as to constitute an effective waiver of lien under the applicable laws of the State of Texas.’

PROJECT: ADDISON RAWHIDE CREEK BASIN DRAINAGE AND ADA IMPROVEMENTS FROM BROOKWOOD DR TO WATERSIDE CT

109.5.1.2. Lien Waivers. Concurrent with each Application for Payment, the Contractor shall execute and furnish a waiver and release of its lien rights current through the effective date of such Application for Payment conditioned upon receipt of the payment that is the subject of the application. Beginning with the second Application for Payment, the Contractor shall also deliver with each such Application as a condition precedent to payment thereof, waivers of lien from each of the Subcontractors, Sub-subcontractors, and suppliers current through the effective date of the previous Application of Payment. The Contractor shall also execute and obtain any other reasonable forms as the Owner may require in order to assure an effective waiver and release of mechanics' and materialmen's liens in compliance with the laws of the State of Texas. The Contractor shall, if any Subcontractor, Sub-subcontractor or supplier refuses to furnish a release in full, furnish a bond satisfactory to the Owner to indemnify against any lien."

R. Section NCTTOG 109.5 of General Provision - Retainage Summary Table:

NCTCOG 109.5.2	
Amount of Contract	% Retainage
\$25,000.00 and less	15%
\$25,000.01 - \$400,000.00	10%
\$400,000.01 or more	5%

90. CONTRACTOR REPRESENTATIONS: By entering into the Contract, the Contractor makes the following representations to the Town of Addison:

- A. Contractor has examined and carefully studied the Bidding Documents and the related data identified in the Bidding Documents.
- B. The Contractor has visited the Project site where the goods are to be installed or services will be provided and become familiar with and is satisfied as to the observable local conditions that may affect cost, progress, or the furnishing of goods and services, if required to do so by the Bidding Documents, or if, in the Contractor's judgment, any local condition may affect cost, progress, or the furnishing of goods and services.
- C. The Contractor is familiar with and is satisfied as to all Laws and Regulations in effect as of the date of the proposal that may affect cost, progress, and the furnishing of goods and services.
- D. The Contractor has carefully studied, considered, and correlated the information known to the Contractor; information commonly known to sellers of similar goods

PROJECT: ADDISON RAWHIDE CREEK BASIN DRAINAGE AND ADA IMPROVEMENTS FROM BROOKWOOD DR TO WATERSIDE CT

doing business in the locality of the Project site where the goods will be installed or where services will be provided; information and observations obtained from the Contractor's visits, if any, to the Project site where the goods will be installed or services will be provided; and any reports and drawings identified in the Bidding Documents regarding the Project site where the goods will be installed or where services will be provided, with respect to the effect of such information, observations, and documents on the cost, progress, and performance of the Contractor's obligations under the Bidding Documents.

- E. The Contractor has given the Engineer written notice of all conflicts, errors, ambiguities, and discrepancies that the Contractor has discovered in the Bidding Documents, and the written resolution (if any) thereof by the Engineer is acceptable to the Contractor.
- F. The Bidding Documents are generally sufficient to indicate and convey understanding of all terms and conditions for furnishing the goods and services for which the proposal is submitted
- G. The Contractor acknowledges that estimated quantities are not guaranteed and are solely for the purpose of comparison of proposals, and final payment for all unit price bid items will be based on actual quantities, determined as provided in the Contract Documents. The Contractor also acknowledges that each unit price includes an amount considered by the Contractor to be adequate to cover the Contractor's overhead and profit for each separately identified item.

91. PREVAILING WAGE RATES: Wage rates paid on this Project shall not be less than specified in the schedule of general prevailing rates of per diem wages as set forth below in the Davis Bacon Act General Decision No. TX130035:

General Decision Number: TX20210025 01/01/2021

Superseded General Decision Number: TX20200025

State: Texas

Construction Type: Highway

Counties: Archer, Callahan, Clay, Collin, Dallas, Delta, Denton, Ellis, Grayson, Hunt, Johnson, Jones, Kaufman, Parker, Rockwall, Tarrant and Wise Counties in Texas.

HIGHWAY CONSTRUCTION PROJECTS (excluding tunnels, building structures in rest area projects & railroad construction; bascule, suspension & spandrel arch bridges designed for commercial navigation, bridges involving marine construction; and other major bridges).

Note: Under Executive Order (EO) 13658, an hourly minimum wage of \$10.95 for calendar year 2021 applies to all contracts subject to the Davis-Bacon Act for which the contract is awarded (and any solicitation was issued) on or after January 1, 2015. If this contract is covered by the EO, the contractor must pay all workers in any classification listed on this wage determination at least

PROJECT: ADDISON RAWHIDE CREEK BASIN DRAINAGE AND ADA IMPROVEMENTS FROM BROOKWOOD DR TO WATERSIDE CT

\$10.95 per hour (or the applicable wage rate listed on this wage determination, if it is higher) for all hours spent performing on the contract in calendar year 2021. If this contract is covered by the EO and a classification considered necessary for performance of work on the contract does not appear on this wage determination, the contractor must pay workers in that classification at least the wage rate determined through the conformance process set forth in 29 CFR 5.5(a)(1)(ii) (or the EO minimum wage rate, if it is higher than the conformed wage rate). The EO minimum wage rate will be adjusted annually. Please note that this EO applies to the above-mentioned types of contracts entered into by the federal government that are subject to the Davis-Bacon Act itself, but it does not apply to contracts subject only to the Davis-Bacon Related Acts, including those set forth at 29 CFR 5.1(a)(2)-(60). Additional information on contractor requirements and worker protections under the EO is available at www.dol.gov/whd/govcontracts.

Modification Number	Publication Date
---------------------	------------------

0	01/01/2021
---	------------

* SUTX2011-007	08/03/2011
----------------	------------

Rates	Fringes
-------	---------

CONCRETE FINISHER (Paving and Structures).....\$ 14.12

ELECTRICIAN.....\$ 19.80

FORM BUILDER/FORM SETTER

Paving & Curb.....\$ 13.16

Structures.....\$ 13.84

LABORER

Asphalt Raker.....\$ 12.69

Flagger.....\$ 10.06

Laborer, Common.....\$ 10.72

Laborer, Utility.....\$ 12.32

Pipelayer.....\$ 13.24

Work Zone Barricade Servicer.....\$ 11.68

POWER EQUIPMENT OPERATOR:

Asphalt Distributor.....\$ 15.32

Asphalt Paving Machine.....\$ 13.99

PROJECT: ADDISON RAWHIDE CREEK BASIN DRAINAGE AND ADA IMPROVEMENTS FROM BROOKWOOD DR TO WATERSIDE CT

Broom or Sweeper.....	\$ 11.74
Concrete Pavement Finishing Machine.....	\$ 16.05
Concrete Saw.....	\$ 14.48
Crane Operator, Lattice Boom 80 Tons or Less.....	\$ 17.27
Crane Operator, Lattice Boom over 80 Tons.....	\$ 20.52
Crane, Hydraulic 80 Tons or Less.....	\$ 18.12
Crawler Tractor.....	\$ 14.07
Excavator, 50,000 pounds or less.....	\$ 17.19
Excavator, over 50,000 pounds.....	\$ 16.99
Foundation Drill , Truck Mounted.....	\$ 21.07
Foundation Drill, Crawler Mounted.....	\$ 17.99
Front End Loader 3 CY or Less.....	\$ 13.69
Front End Loader, over 3 CY.....	\$ 14.72
Loader/Backhoe.....	\$ 15.18
Mechanic.....	\$ 17.68
Milling Machine.....	\$ 14.32
Motor Grader, Fine Grade....	\$ 17.19
Motor Grader, Rough.....	\$ 16.02
Pavement Marking Machine....	\$ 13.63
Reclaimer/Pulverizer.....	\$ 11.01
Roller, Asphalt.....	\$ 13.08
Roller, Other.....	\$ 11.51
Scraper.....	\$ 12.96
Small Slipform Machine.....	\$ 15.96
Spreader Box.....	\$ 14.73

PROJECT: ADDISON RAWHIDE CREEK BASIN DRAINAGE AND ADA IMPROVEMENTS FROM BROOKWOOD DR TO WATERSIDE CT

Servicer.....\$ 14.58

Steel Worker (Reinforcing).....\$ 16.18

TRUCK DRIVER

Lowboy-Float.....\$ 16.24

Off Road Hauler.....\$ 12.25

Single Axle.....\$ 12.31

Single or Tandem Axle Dump Truck.....\$ 12.62

Tandem Axle Tractor with Semi Trailer.....\$ 12.86

Transit-Mix.....\$ 14.14

WELDER.....\$ 14.84

WELDERS - Receive rate prescribed for craft performing operation to which welding is incidental.

=====

Note: Executive Order (EO) 13706, Establishing Paid Sick Leave for Federal Contractors applies to all contracts subject to the Davis-Bacon Act for which the contract is awarded (and any solicitation was issued) on or after January 1, 2017. If this contract is covered by the EO, the contractor must provide employees with 1 hour of paid sick leave for every 30 hours they work, up to 56 hours of paid sick leave each year. Employees must be permitted to use paid sick leave for their own illness, injury or other health-related needs, including preventive care; to assist a family member (or person who is like family to the employee) who is ill, injured, or has other health-related needs, including preventive care; or for reasons resulting from, or to assist a family member (or person who is like family to the employee) who is a victim of, domestic violence, sexual assault, or stalking. Additional information on contractor requirements and worker protections under the EO is available at www.dol.gov/whd/govcontracts.

Unlisted classifications needed for work not included within the scope of the classifications listed may be added after award only as provided in the labor standards contract clauses (29CFR 5.5 (a) (1) (ii)).

The body of each wage determination lists the classification and wage rates that have been found to be prevailing for the cited type(s) of construction in the area covered by the wage determination. The classifications are listed in alphabetical order of ""identifiers"" that indicate whether the particular rate is a union rate (current union negotiated rate for local), a survey rate (weighted average rate) or a union average rate (weighted union average rate).

Union Rate Identifiers

PROJECT: ADDISON RAWHIDE CREEK BASIN DRAINAGE AND ADA IMPROVEMENTS FROM BROOKWOOD DR TO WATERSIDE CT

A four-letter classification abbreviation identifier enclosed in dotted lines beginning with characters other than ""SU"" or ""UAVG"" denotes that the union classification and rate were prevailing for that classification in the survey. Example:

PLUM0198-005 07/01/2014. PLUM is an abbreviation identifier of the union which prevailed in the survey for this classification, which in this example would be Plumbers. 0198 indicates the local union number or district council number where applicable, i.e., Plumbers Local 0198. The next number, 005 in the example, is an internal number used in processing the wage determination. 07/01/2014 is the effective date of the most current negotiated rate, which in this example is July 1, 2014.

Union prevailing wage rates are updated to reflect all rate changes in the collective bargaining agreement (CBA) governing this classification and rate.

Survey Rate Identifiers

Classifications listed under the ""SU"" identifier indicate that no one rate prevailed for this classification in the survey and the published rate is derived by computing a weighted average rate based on all the rates reported in the survey for that classification. As this weighted average rate includes all rates reported in the survey, it may include both union and non-union rates. Example: SULA2012-007 5/13/2014. SU indicates the rates are survey rates based on a weighted average calculation of rates and are not majority rates. LA indicates the State of Louisiana. 2012 is the year of survey on which these classifications and rates are based. The next number, 007 in the example, is an internal number used in producing the wage determination. 5/13/2014 indicates the survey completion date for the classifications and rates under that identifier.

Survey wage rates are not updated and remain in effect until a new survey is conducted.

Union Average Rate Identifiers

Classification(s) listed under the UAVG identifier indicate that no single majority rate prevailed for those classifications; however, 100% of the data reported for the classifications was union data. EXAMPLE: UAVG-OH-0010 08/29/2014. UAVG indicates that the rate is a weighted union average rate. OH indicates the state. The next number, 0010 in the example, is an internal number used in producing the wage determination. 08/29/2014 indicates the survey completion date for the classifications and rates under that identifier.

A UAVG rate will be updated once a year, usually in January of each year, to reflect a weighted average of the current negotiated/CBA rate of the union locals from which the rate is based.

WAGE DETERMINATION APPEALS PROCESS

1.) Has there been an initial decision in the matter? This can be:

* an existing published wage determination

PROJECT: ADDISON RAWHIDE CREEK BASIN DRAINAGE AND ADA IMPROVEMENTS FROM BROOKWOOD DR TO WATERSIDE CT

- * a survey underlying a wage determination
- * a Wage and Hour Division letter setting forth a position on a wage determination matter
- * a conformance (additional classification and rate) ruling

On survey related matters, initial contact, including requests for summaries of surveys, should be with the Wage and Hour Regional Office for the area in which the survey was conducted because those Regional Offices have responsibility for the Davis-Bacon survey program. If the response from this initial contact is not satisfactory, then the process described in 2.) and 3.) should be followed.

With regard to any other matter not yet ripe for the formal process described here, initial contact should be with the Branch of Construction Wage Determinations. Write to:

Branch of Construction Wage Determinations
Wage and Hour Division
U.S. Department of Labor
200 Constitution Avenue, N.W.
Washington, DC 20210

2.) If the answer to the question in 1.) is yes, then an interested party (those affected by the action) can request review and reconsideration from the Wage and Hour Administrator (See 29 CFR Part 1.8 and 29 CFR Part 7). Write to:

Wage and Hour Administrator
U.S. Department of Labor
200 Constitution Avenue, N.W.
Washington, DC 20210

The request should be accompanied by a full statement of the interested party's position and by any information (wage payment data, project description, area practice material, etc.) that the requestor considers relevant to the issue.

3.) If the decision of the Administrator is not favorable, an interested party may appeal directly to the Administrative Review Board (formerly the Wage Appeals Board). Write to:

Administrative Review Board
U.S. Department of Labor
200 Constitution Avenue, N.W.
Washington, DC 20210

4.) All decisions by the Administrative Review Board are final.

=====

**PROJECT: ADDISON RAWHIDE CREEK BASIN DRAINAGE AND ADA IMPROVEMENTS FROM
BROOKWOOD DR TO WATERSIDE CT**

END OF GENERAL DECISION

- 92. NO BOYCOTT ISRAEL:** Pursuant to Texas Government Code Chapter 2270, Contractor's execution of this Agreement shall serve as verification that the Contractor does not presently boycott Israel and will not boycott Israel during the term of this Agreement.

END OF GENERAL DECISION

PROJECT: ADDISON RAWHIDE CREEK BASIN DRAINAGE AND ADA IMPROVEMENTS FROM BROOKWOOD DR TO WATERSIDE CT

SPECIAL PROVISIONS

Note: The series of numbers shown after the description are for the North Central Texas Council of Governments (NCTCOG) Standard Specifications for Public Works Construction, Fifth Edition (November 2017- Current Edition)), or technical specifications number provided with this document.

SP.1 PROJECT

The project covered by these specifications consists of the furnishing and installation of all material, supplies, appurtenances, equipment and labor and any other necessary items required to construct, test and complete, ready for use and operation by the Owner. Final clean up before acceptance by the Owner is included as a part of the project.

SP.2 NCTCOG CONSTRUCTION SPECIFICATIONS

NCTCOG shall be utilized for these areas:

- Site Protection & Preparation Division 200
- Roadway Construction Division 300
- Roadway Maintenance & Rehabilitation Division 400
- Underground Construction and appurtenances Division 500
- Conduit and Appurtenances Division 600
- Structures Division 700
- Misc. Construction & Materials Division 800

The specifications included with this document govern if there are any discrepancies between them and the listed specifications.

SP.3 DISPOSAL OF SURPLUS MATERIAL

The Town will have first rights-of-refusal for existing equipment that will be disposed. Surplus material not required for other parts of the work and not otherwise specifically covered by the drawings or specifications shall become the property of the Contractor for proper disposal by him.

2:55:00 PM 8/18/22 I:\s1\data\PROJECT\14799.00_Addison_Rawhide-Creek-Basin-Drainage\07_DGN\076_Sheets\076-01_General\14799GN-QUA01.dgn

SUMMARY OF QUANTITY			
Item #	Bid Qty.	Unit	Description
General			
1	1	LS	Mobilization (5% Max)
2	2	EA	Project Sign
3	1	LS	Barricades, Signs, and Traffic Handling
4	1	AL	Construction Contingency Allowance Owner Approval
Paving			
5	3,498	SY	Remove & Dispose of Existing Pavement
6	3,265	SY	8-Inch Reinforced Concrete Pavement
7	1,021	SY	Remove & Dispose Concrete Sidewalk
8	893	SY	4-Inch Reinforced Concrete Sidewalk
9	233	SY	6-Inch Reinforced Concrete Driveway
10	3,500	SY	8" Flexible Base
11	1,460	LF	6" Monolithic Curb
12	1	EA	Stabilized Construction Entrance
13	2	EA	Remove and Dispose Masonry Mailbox
14	2	EA	Remove and Relocate Masonry Mailbox
15	11	EA	Barrier Free Ramp
Storm Drainage			
16	54	LF	Remove and Dispose of Existing 18" RCP
17	50	LF	Remove and Dispose of Existing 24" RCP
18	484	LF	Remove and Dispose of Existing 42" RCP
19	325	LF	Remove and Dispose of Existing 48" RCP
20	3	EA	Remove and Dispose of Existing Curb Inlet
21	9	SY	Remove and Dispose of Existing Conc Inlet Apron
22	10	SY	Construct Conc Inlet Apron
23	2,072	LF	Trench Safety
24	88	LF	18-Inch Class III RCP
25	922	LF	24-Inch Class III RCP
26	334	LF	36-Inch Class III RCP
27	12	LF	42-Inch Class III RCP
28	66	LF	48-Inch Class III RCP
29	143	LF	48-Inch HDPE (Smooth Walls)
30	507	LF	5'x3' Class C Conc RCB (Precast)
31	7	EA	10-Foot Concrete Curb Inlet
32	1	EA	12'x10' Junction Box Structure
33	3	EA	4'x4' Storm Water Manhole
34	1	EA	5'x5' Storm Water Manhole
35	3	EA	6'x6' Storm Water Manhole
36	1	LS	StormTrap Detention System
37	1	LS	Storm Water Pollution Prevention Plan (SW3P) - Including Maintenance, Inlet Protection, and Erosion Control
38	2,072	LF	Television Inspection
Water/Wastewater			
39	2	EA	Concrete Casing Around Sanitary Sewer
40	2	EA	Adjustment to Water Valve
41	2	EA	Water Main Lowering
42	2	EA	8" Water Main Crossing (By Open Cut)
43	1	EA	12" Water Main Crossing (By Open Cut)
44	9	EA	Furnish & Install 1" Standard Water Service

Landscaping			
45	2,050	SY	Block Sod
46	2,050	SY	Top Soil (4" Depth)
47	7	EA	Remove Trees
48	1	EA	Irrigation (Replace Sprinkler Heads)
49	5	EA	Standard Town Bollard
50	2	EA	Bench
51	1	EA	Trash Receptacle
52	1	EA	Pet Waste Station
53	1	AL	Town Standard Trail Signage
54	355	LF	Steel Edging
55	2	EA	Wrought Iron Gate (4' W x 4' H)
56	2	EA	Canopy Tree
57	3	EA	Ornamental Tree
58	150	EA	5 Gallon Shrub
59	16	EA	3 Gallon Shrub
60	2,171	EA	1 Gallon Shrub
61	8,860	SF	Soil Prep/Mulch
62	8,860	SF	Irrigation



Sherry L. Williams, P.E.
06/24/2022

REV. NO.	DATE	DESCRIPTION	BY
1	8/18/22	ADDENDUM #1 - REVISED UNIT LABEL	JC



CRIADO 4100 SPRING VALLEY ROAD, SUITE 1001
DALLAS, TX 75244
O: 972-392-9092 F: 972-392-9192
FIRM NO. F-4373

SUMMARY OF QUANTITY SHEET						
ADDISON RAWHIDE BASIN DRAINAGE AND SIDEWALK IMPROVEMENTS						
TOWN OF ADDISON, TEXAS						
DESIGN	DRAWN	DATE	SCALE	NOTES	FILE	NO.
CRIADO	CRIADO	MAY 2022	AS SHOWN	R14799.00		

BENCHMARKS & CONTROL POINTS				
POINT	NORTHING	EASTING	ELEVATION	DESCRIPTION
COA-1	7028890.84	2473021.89	573.15	LOCATED OFF-SITE
COA-3	7032377.29	2472935.19	585.42	LOCATED OFF-SITE
CP 806	7030924.57	2473583.64	592.49	5/8" IRON ROD SET WITH REC CAP STAMPED "CRIADO"
CP 809	7030990.12	2473974.85	591.48	5/8" IRON ROD SET WITH REC CAP STAMPED "CRIADO"

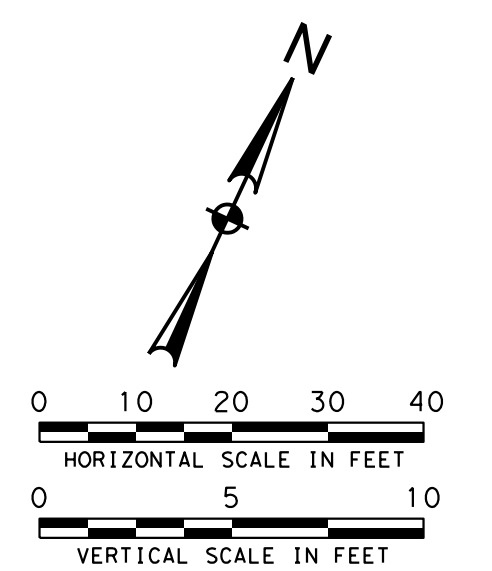

- LEGEND**
- PROPOSED STORM DRAIN
 - PROPOSED INLET
 - PROPOSED MANHOLE
 - EXISTING STORM DRAIN
 - EXISTING INLET
 - EXISTING SANITARY SEWER

- NOTES:**
- UNLESS NOTED, UTILITY CROSSING LOCATIONS BASED ON ASSUMED DEPTHS AND SHALL BE UNCOVERED AND VERIFIED BY CONTRACTOR PRIOR TO START OF CONSTRUCTION
 - SLOPES SHOWN BASED ON HYDRAULIC LENGTH OF PIPE SEGMENT (CENTER OF NODE TO CENTER OF NODE) LENGTHS SHOWN ARE ACTUAL LENGTH OF PIPE
 - INLET CONTROL POINT STA/OFF SHOWN AT CENTER LINE OF INLET BOX AT BACK OF CURB
 - POSITIVE DRAINAGE TO BE MAINTAINED AT ALL TIMES
 - TOWN INSPECTOR WILL DETERMINE FINAL PAVEMENT REMOVAL LIMITS. ACTUAL LIMITS OF REMOVAL MAY VARY BASED ON SITE CONDITIONS
 - CONTRACTOR TO FIELD VERIFY HORIZONTAL AND VERTICAL LOCATION OF EXISTING STORM DRAIN PIPES PRIOR TO EXCAVATION
 - EXISTING STORM DRAIN PIPES ARE SHOWN PER RECORD DRAWINGS FOR DEVELOPMENT PLANS FOR GRAND ADDISON II AND III AND WATERFORD PARK II

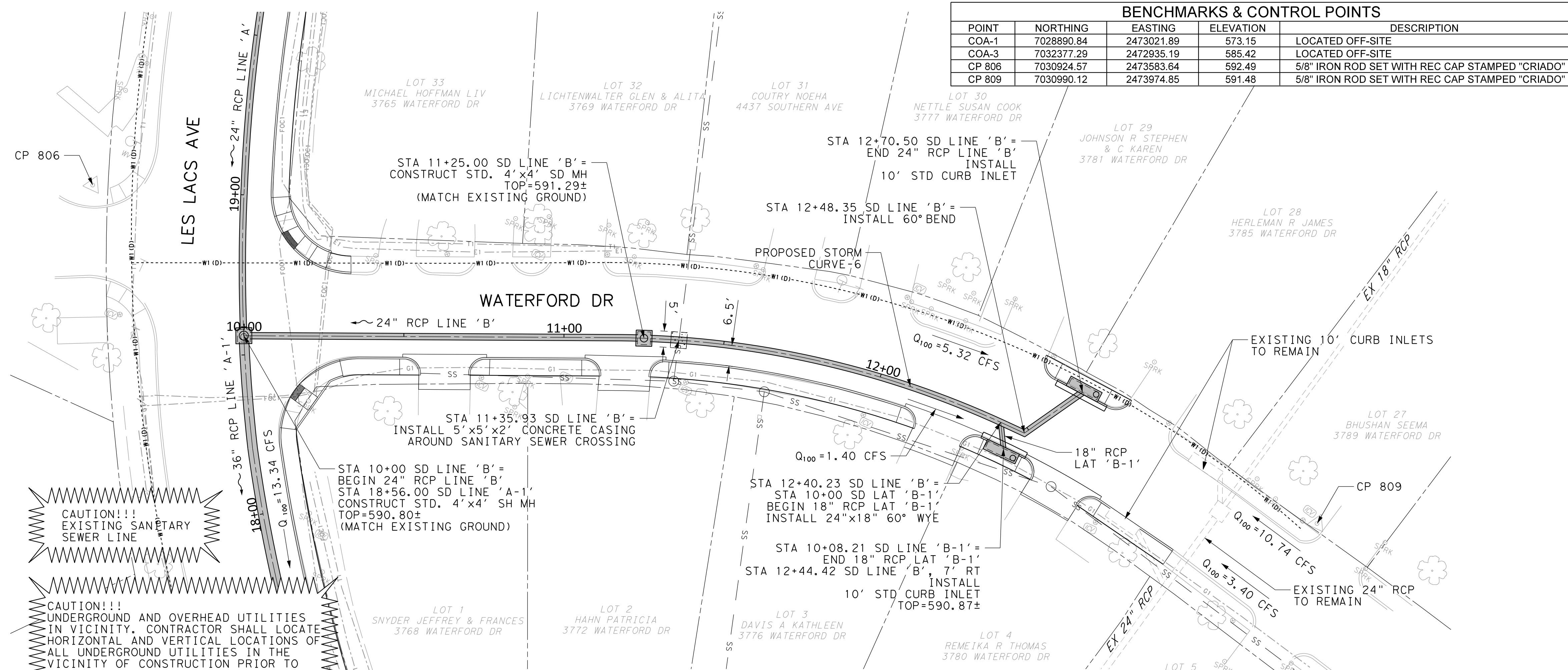

ADDISON RAWHIDE PROPOSED STORM - CURVE DATA								
CURVE	PI STATION	DELTA	DEGREE	TANGENT	LENGTH	RADIUS	PC STATION	PT STATION
PROPOSED STORM CURVE-6	11+80.13	24° 37' 19.38" (RT)	19° 31' 17.62"	64.05'	126.13'	293.50'	11+16.07	12+42.20

CAUTION!!!
EXISTING SANITARY SEWER LINE

CAUTION!!!
UNDERGROUND AND OVERHEAD UTILITIES IN VICINITY. CONTRACTOR SHALL LOCATE HORIZONTAL AND VERTICAL LOCATIONS OF ALL UNDERGROUND UTILITIES IN THE VICINITY OF CONSTRUCTION PRIOR TO COMMENCING WORK.

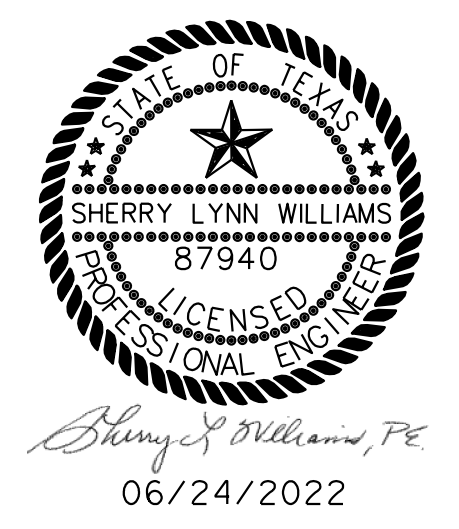

REV. NO.	DATE	DESCRIPTION	BY
1	8/18/22	ADDENDUM #1 - REVISED NOTE	JC



CRIADO 4100 SPRING VALLEY ROAD, SUITE 1001
DALLAS, TX 75244
O: 972-392-9092 F: 972-392-9192
FIRM NO. F-4373

DRAINAGE PLAN & PROFILE
SD LINE 'B' BEGIN TO END
ADDISON RAWHIDE BASIN
DRAINAGE AND SIDEWALK IMPROVEMENTS
TOWN OF ADDISON, TEXAS

DESIGN	DRAWN	DATE	SCALE	NOTES	FILE	NO.
CRIADO	CRIADO	MAY 2022	AS SHOWN	R14799.00		

8:00:05 PM C:\Users\jwilliams\OneDrive\Desktop\PROJECTR14799.00_Addison_Rawhide-Creek-Basin-Drainage\07_DGN\076_Sheets\076-05_Drainage\14799-DRN-PP-04.dgn

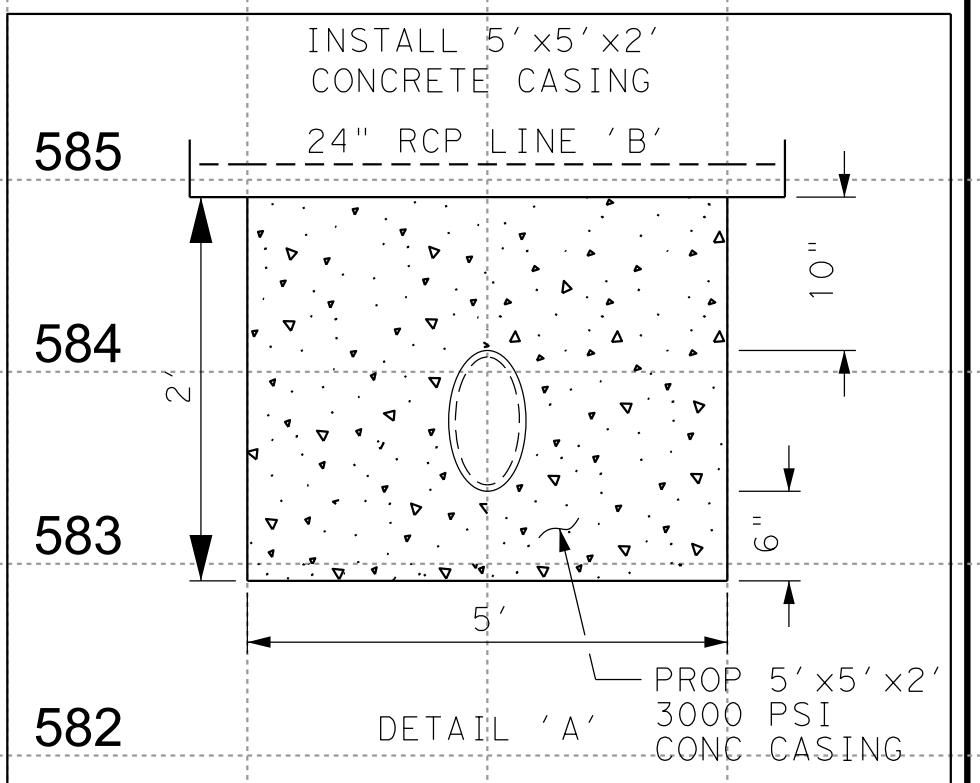
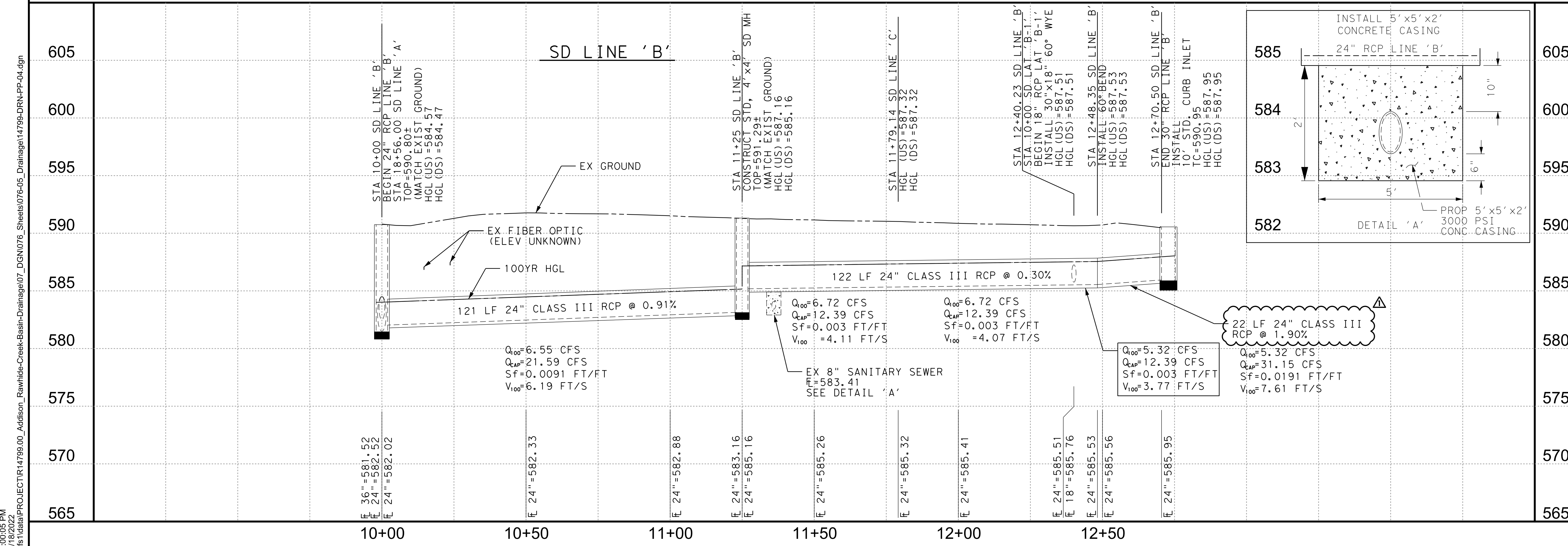

22 LF 24" CLASS III RCP @ 1.90%